

# Sectional Doors

## - ECO DOOR -

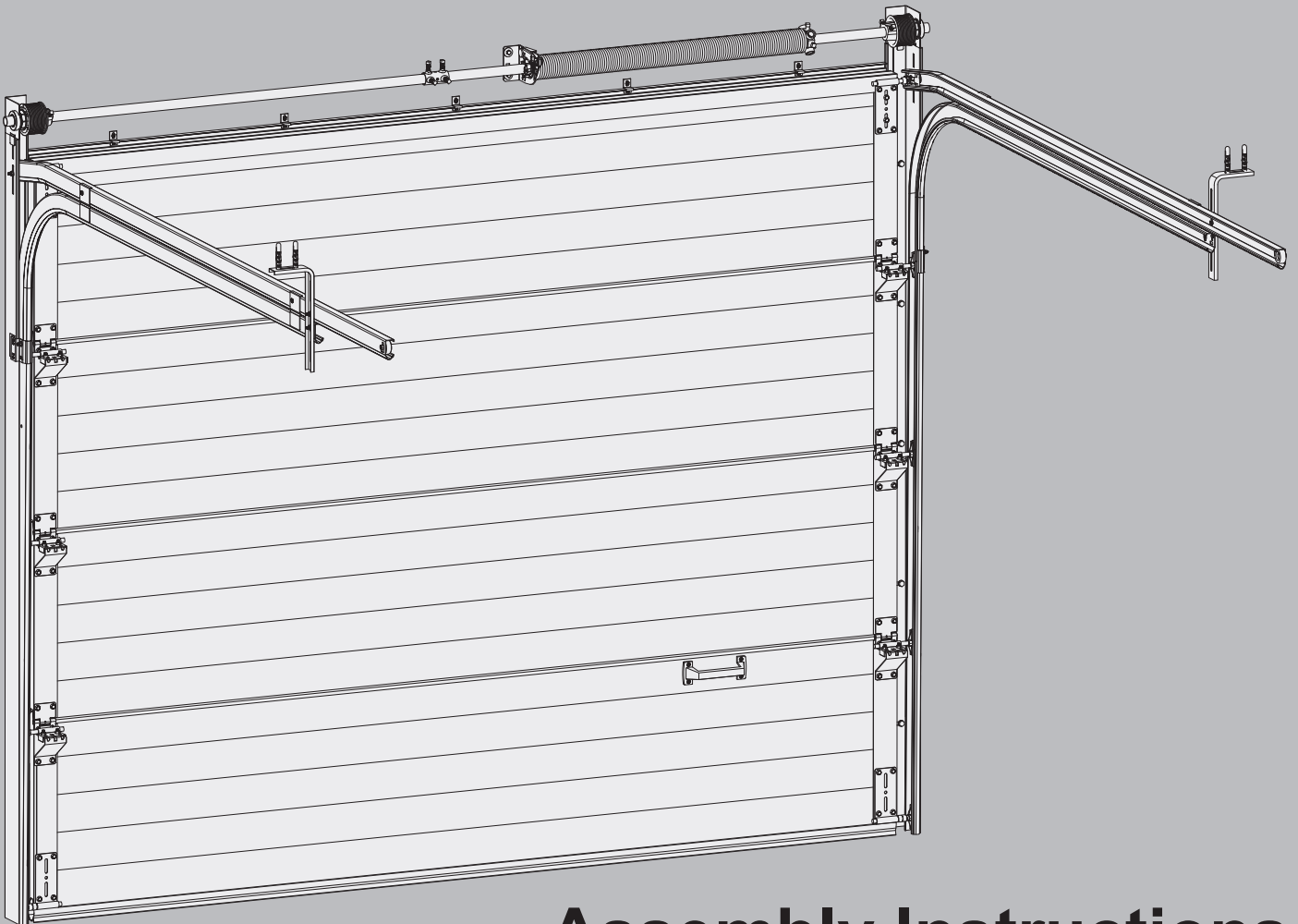

## Assembly Instructions



**flexidoor**<sup>®</sup>  
AUTOMATIC DOORS MANUFACTURER



**REV 01.01G**

06/2022

# INDEX

<b>General warnings</b> .....	3
<b>Necessary tools for the installation</b> .....	4
<b>Parts list</b> .....	4
<b>1. Verifications</b> .....	6
1.1 Verification of received packs .....	6
1.2 Verification of door dimensions .....	6
1.3 Before begin installation .....	6
1.4 Wall type .....	7
<b>2. Door frame assembly</b> .....	7
2.1 Vertical angles assembly .....	7
2.2 Fixation of the left vertical angle .....	9
2.3 Fixation of second vertical angle .....	12
2.4 Top profile assembly .....	13
2.5 Fixation the top profile .....	14
2.6 Fixation of the horizontal tracks to the vertical angles .....	15
2.7 Fixation of the horizontal tracks to the ceiling .....	17
<b>3. Shaft and springs assembly</b> .....	18
3.1 Shaft assembly .....	18
3.2 Fixing the shaft to the vertical angles .....	20
3.3 Fixation of the shaft in the headroom .....	22
3.4 Installation of the spring break device .....	23
<b>4. Door panels assembly</b> .....	25
4.1 Bottom panel assembly .....	25
4.2 Second panel assembly .....	28
4.3 Third panel assembly .....	30
4.4 Top panel assembly .....	31
4.5 Installation of the handle .....	32
4.6 Fixation of the rubber stop on the horizontal tracks .....	33
<b>5. Installation of the cables</b> .....	34
<b>6. Adjustments</b> .....	35
6.1 Spring tension .....	35
6.2 Top roller bracket adjustment .....	39
6.3 Conclusion of the installation of the door .....	39
<b>7. Sectional door general view</b> .....	40
<b>8. Maintenance and replacement parts</b> .....	43
<b>9. Troubleshooting</b> .....	45
<b>10. Motor installation</b> .....	45
<b>11. Instructions for operation and use</b> .....	46
11.1 Documentation delivered .....	46
11.2 User instructions .....	46
11.3 Operating instructions .....	46
<b>12. Dismantling the sectional door</b> .....	47
<b>Warranty</b> .....	48
<b>Warranty of springs</b> .....	49
<b>Book for registry of maintenance</b> .....	50

Safety warnings or remarks are indicated with the symbol:



It is used to alert the user to potential risks.

All safety messages that follow this sign must be observed to avoid possible harm. Please read these warnings carefully.

### GENERAL WARNINGS

To install, use and maintain all the hardware of the sectional door with security, there must be taken some precaution measures. To ensure the safety of persons and goods, please follow the procedures described in this manual. If in doubt contact your supplier.

This manual was designed for use by professional installers or people with experience; it is not indicated for apprentices.

This manual describes the installation of the hardware set components, door sections (panels) and refers to installation manuals of the electrical operator. Be sure to supplement this manual if needed with instructions for any additional components not described in this manual.

Before starting, read this manual carefully!

All the components which have been supplied are designed for use with this specific overhead door. Replacement or adding additional components may have an adverse effect on the safety of, and the guarantee on, the door, if not approved by Flexidoor. Also the CE-approval which has been granted to this door will be cancelled when components are changed or installation is not done according to this manual! Installer is responsible for this.

Verify that the structure where the door will be installed meets the necessary requirements of strength and stability.

 **Certain components may be sharp or have jagged edges. As such you are advised to wear safety gloves. In case of drilling or cutting, wear safety glasses and safety shoes.**



During tensioning, springs can exert large forces. Work carefully. Use the proper equipment. Ensure that you are standing in a steady position.

Ensure that there is sufficient light during installation. Remove obstacles and dirt. Make sure that there is no one else present other than the fitters. Other people (children!) may get in the way or endanger themselves during the installation.

Safety devices for automated doors (such as photocells, pressure-sensitive or electro-sensitive devices) as the regulation of closing forces shall be installed / verified taking into account the technical regulations, European standards and guidelines in force available, where the requirements of some points of the European standards EN 12604, EN 12445 and EN 12453 must be met by the installer.

Do not allow children or unqualified persons to operate this door, they may be in danger in handling the door. Failure to install any of the components of protection by the installer, referred to by the manufacturer or by the European standards, declines any responsibility to the manufacturer of the door, if any accident occurs.

The installer must be provided with tools that are indispensable for proper and safe installation of the door.



**ATTENTION:** Torsion springs can be very dangerous if they are improperly installed or mishandled. Do not try to install them yourself unless 1) you have the right tools and skills or sufficient mechanical experience and 2) whether you follow these instructions precisely.



**ATTENTION:** Make sure that all screws are securely fastened. Unscrewing screws can cause serious injury.



**ATTENTION:** To avoid injuries, keep hands and fingers away from the section joints, panels, hinges, tracks, springs and other parts of the door while the door is moving.



**ATTENTION:** Ne placez pas vos doigts entre les différentes sections de la porte. Si vous devez ouvrir ou fermer la porte manuellement, utilisez les poignées ou les boutons.

## Necessary tools for the installation

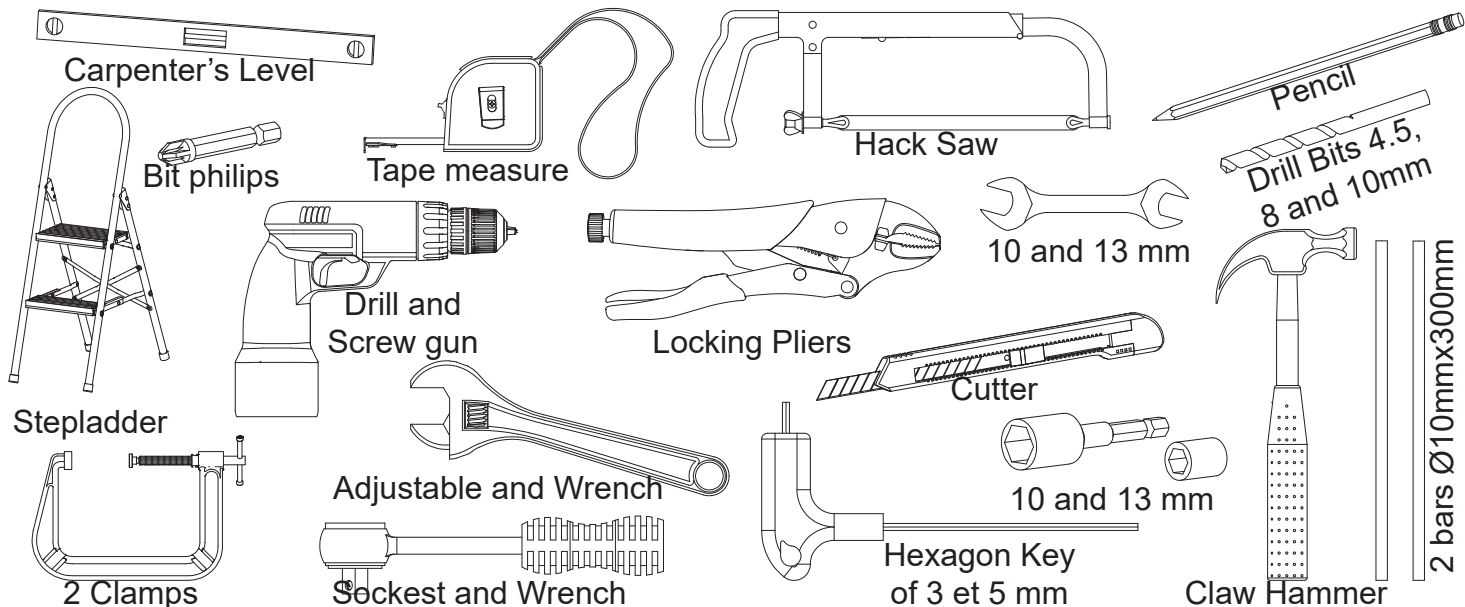

## Parts list

N.º	Reference	Part Name	N.º	Reference	Part Name
1	ROLEPEQ001	Nylon roller	31	CHACANVER170X8-D	Right vertical angle
2	ANIENC	Distance ring	32	CHACANVER170X8-G	Left vertical angle
3	PAR63x25AP	Selldrilling screw 6.3x25	33	CAV006AE	Side Hinge
6	PARUNICURGUI	Press bolt M6x16mm	35	PAI + See door serial nr.	Panel 40 mm
8	TRIM8x50S	Bolt M8x50mm	37	PUXASASIMPLES	Inside wing handle
9	BUCLPA10	Nylon bushing 10	38	DESVEI	Coupling
10	PARM6x16	Oval head screw M6x16	40	CABACO3	Steel cable
11	PORM6FR	M6 Nut	42	CAV006AE	Roller support
13	MOL + See door serial nr.	Torsion spring	44	ANIM8	Washer M8
14	TRAMOL50E01	Left spring break device	45	PROROL580	Roller protection
16	TAMNL76	Right cable drum	46	VEITUB1500	Shaft tube 25,4mm with L=1500
17	BUCKET8	Metal plug M8x50mm	60	31F	Top sealing profile
18	VEITUB1200	Shaft tube 25,4mm with L=1200mm	61	BORLAT001	Top rubber seal L=2500mm
19	TAMN76	Left cable drum	62	31K	Support for profile of the top seal in headroom
20	ROLAPVC	Plastic bearing	63	BATPORCOR	Rubber stop
22	ROLA001	Bearing	66	PAR42X38PEMF	Screw M4,2x38 for interior handle
23	CHAROLSUP001	Top roller bracket	67	BORLAT001	Lateral rubber seal L=2155mm
25	LSUPLIG	Support L for horizontal tracks to the ceiling	68	BUCNYM8PAV	Nylon bushing 8x40
26	CHAGUICUR108X12-D + CHAGUICUR108x1-D	Right horizontal track with curve	69	PARM5X40	Screw 5x40
27	CHAGUICUR108X12-G + CHAGUICUR108x1-G	Left horizontal track with curve			

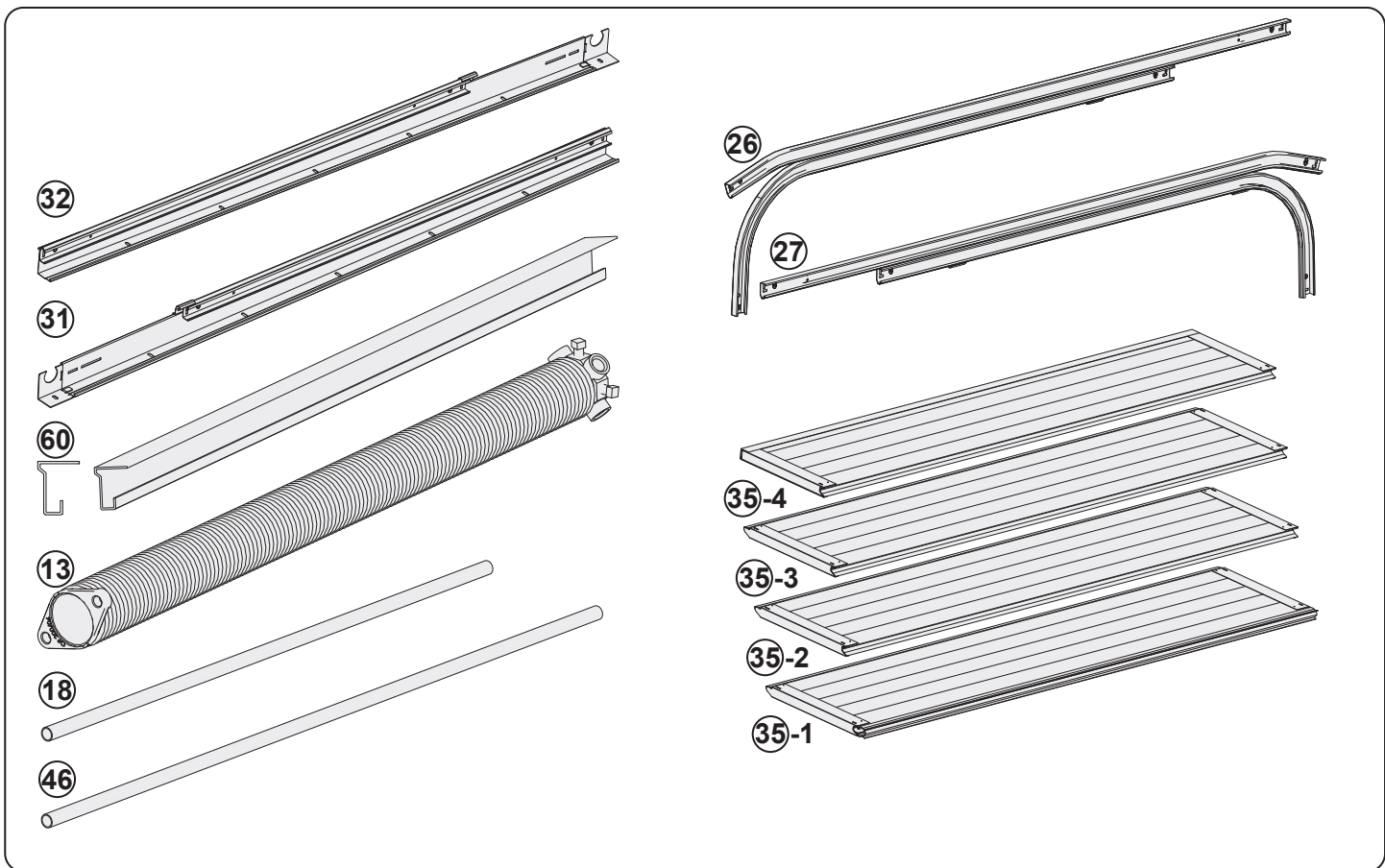
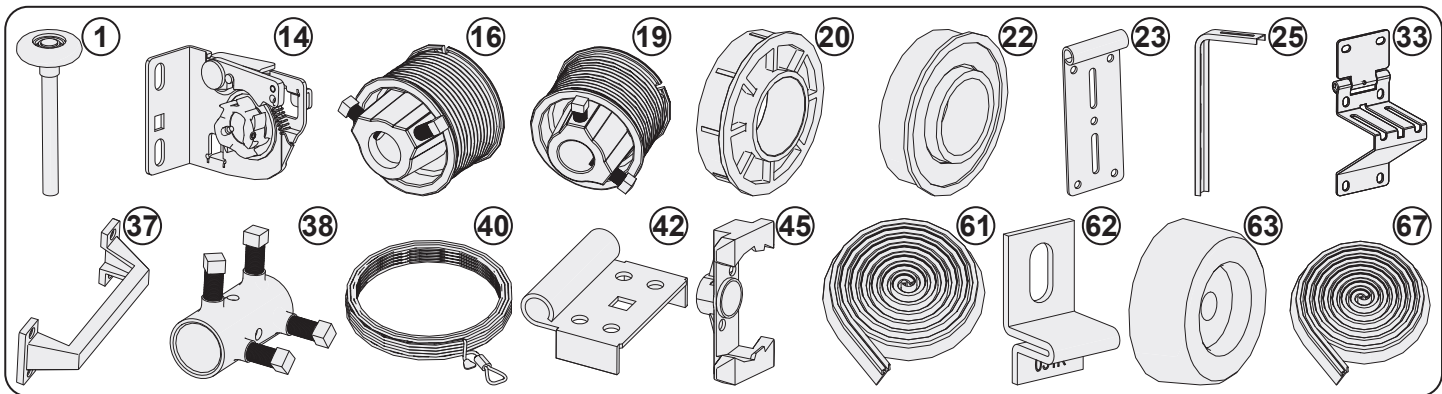
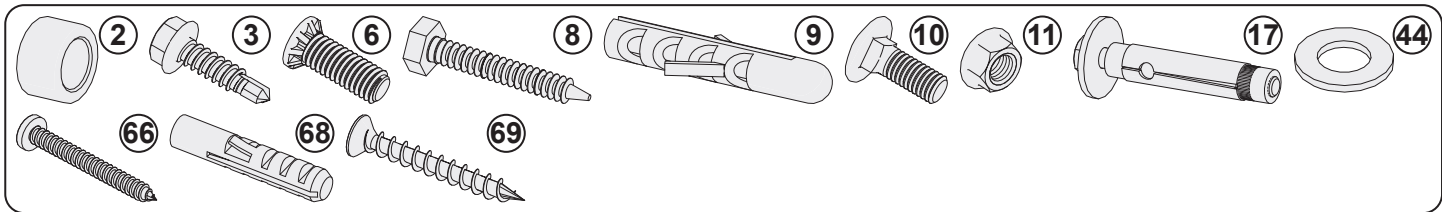

# 1. Verifications

## 1.1 Verification of received packs

Before starting the installation of the door, make sure you have all the material required for installation, and if the door has the appropriate measures to the place where it will be installed.

You must register the O.F. number (serial number) in the following table. The O.F. number will always be asked, on issues related to the door warranty. The O.F. number is recorded in the third panel of the door present in the third package.

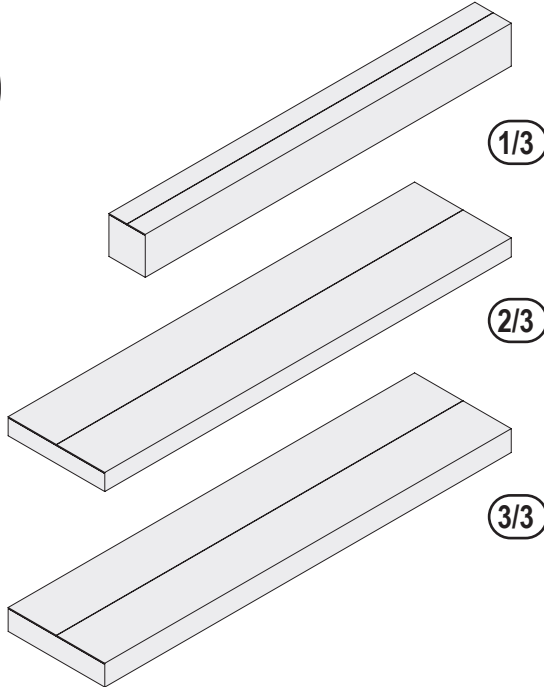

O.F.: \_ \_ \_ / \_ \_ / \_ \_

### Package n°1/3:

- Vertical angles and vertical door track kit
- Spring and shaft kit
- Motor kit
- Hardware box

### Package n°2/3:

- Panels: 1 and 4
- Top profile

### Package n°3/3:

- Panels: 2 and 3
- Horizontal tracks with curves kit

## 1.2 Verification of door dimensions

<b>A</b>	Left sideroom	$\geq 100$
<b>B</b>	Right sideroom	$\geq 100$
<b>C</b>	Backroom	$\geq 3200$
<b>H</b>	Clear opening height	$\leq 2000$
<b>L</b>	Clear opening width	$\leq 2400$
<b>P</b>	Headroom	$\geq 180$
<b>HT</b>	Total height	$\geq 2180$
<b>LT</b>	Total width	$\geq 2600$

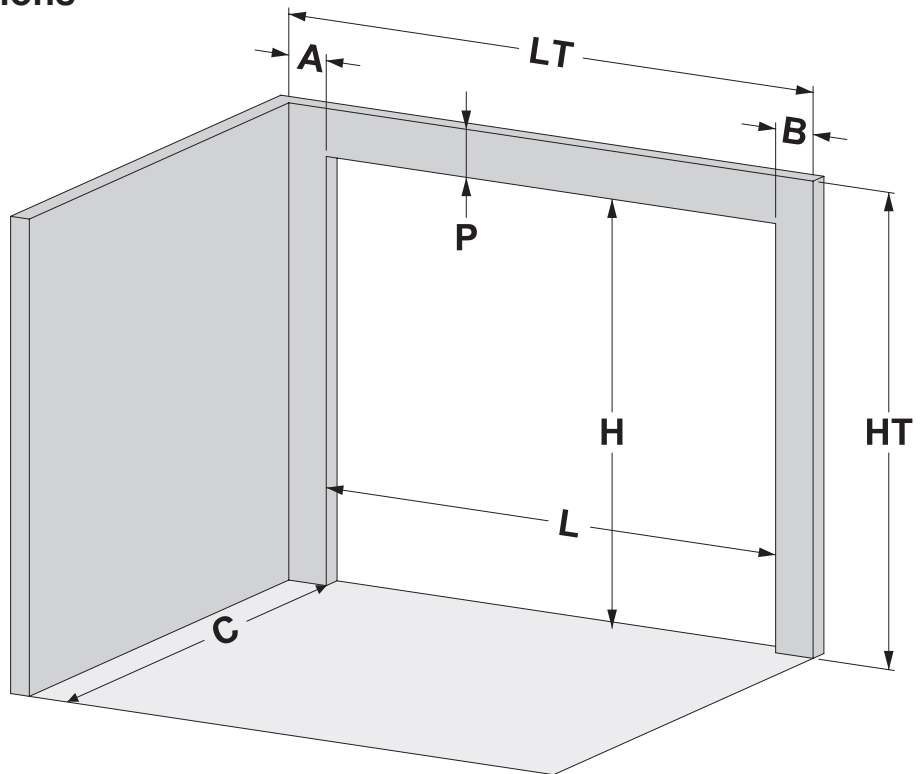

## 1.3 Before begin installation

For correct installation of the sectional door, follow the order in this installation manual.

**Step 1:** Fixation of the left vertical angle.

**Step 2:** Fixation of the horizontal tracks.

**Step 3:** Fixation of the shaft .

**Step 4:** Fixation of the door panels.

## 1.4 Wall type

 It is the responsibility of the installer to identify the material which will be fixed the door and make sure that the way is fixed to the structure is safe and appropriate.

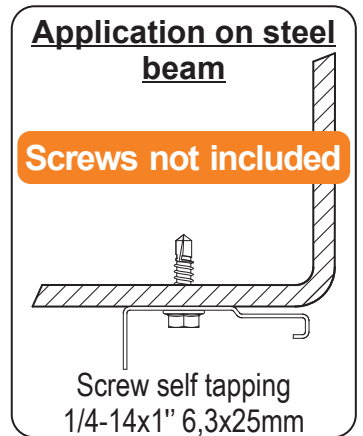
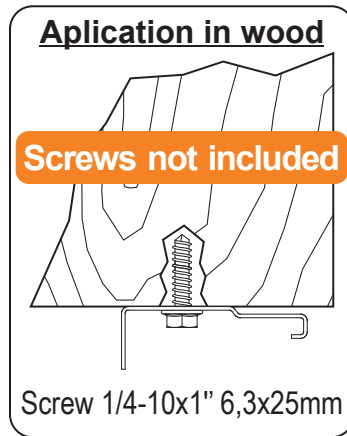
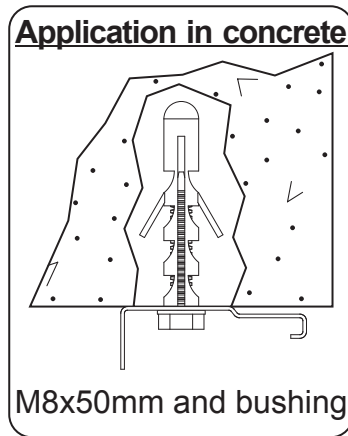
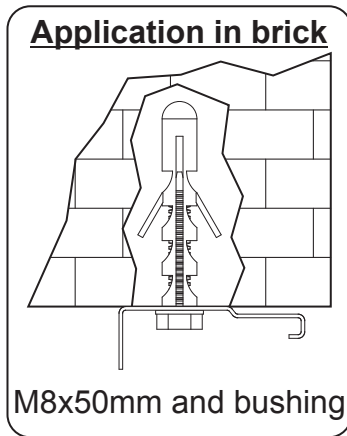

## 2. Door frame assembly

 Make sure that the door and screws are properly secured. The loosening screws can cause serious injury.



Even after being warned about the risk of cuts at the design level, there must be much attention concerning the handling of sheet metal parts with a reduced thickness. Thus, as these risks have not been completely eliminated, a warning is provided.

### 2.1 Vertical angles assembly

2.1.1 Assemble the lateral rubber seal (67) on the vertical angles (31 and 32).

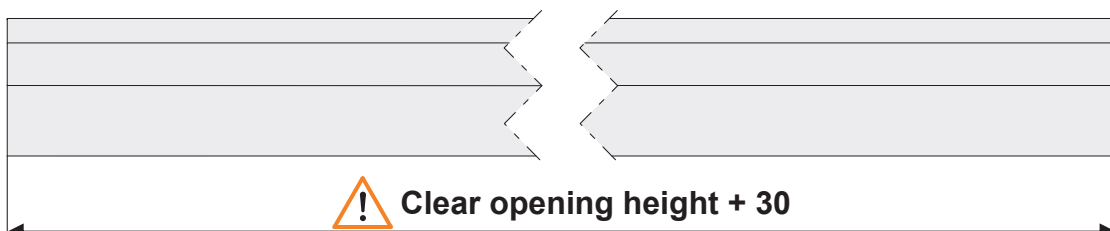
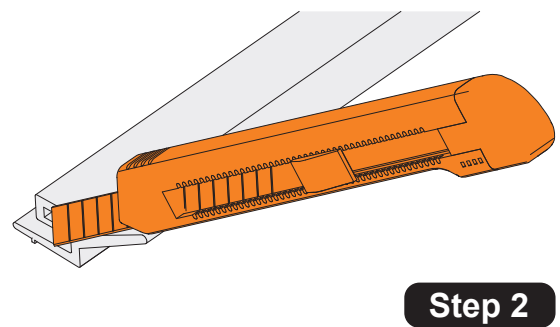
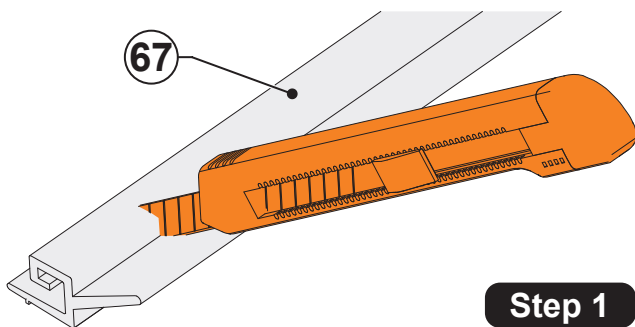
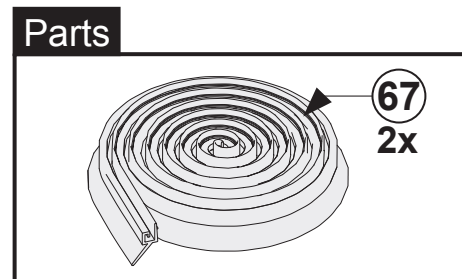
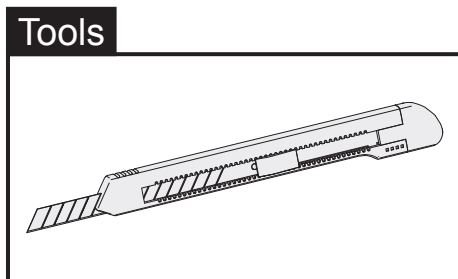

2.1.2 Assemble the lateral rubber seal (67) on the vertical angles (31 and 32).

Parts

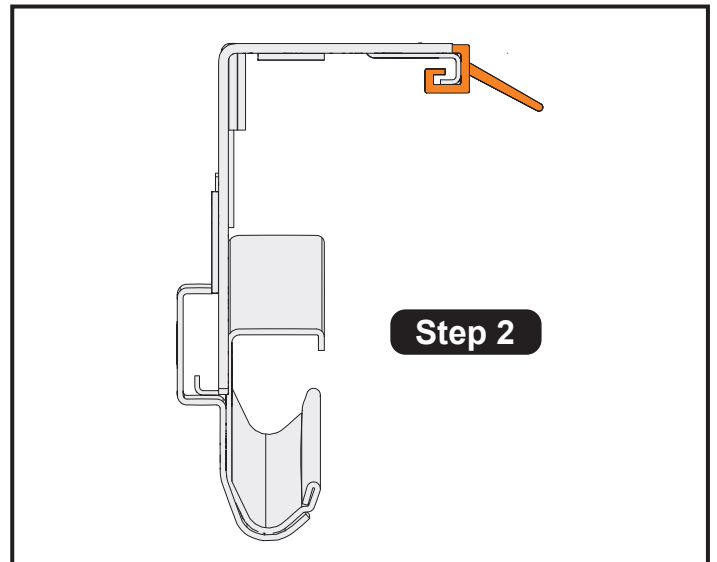
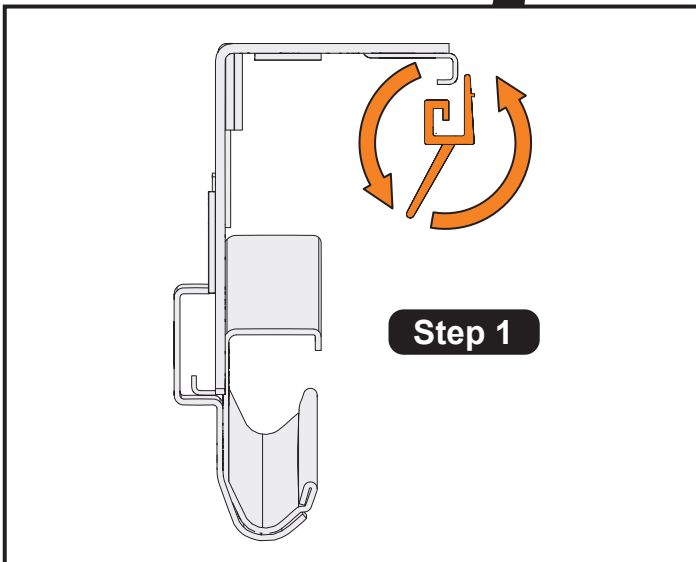
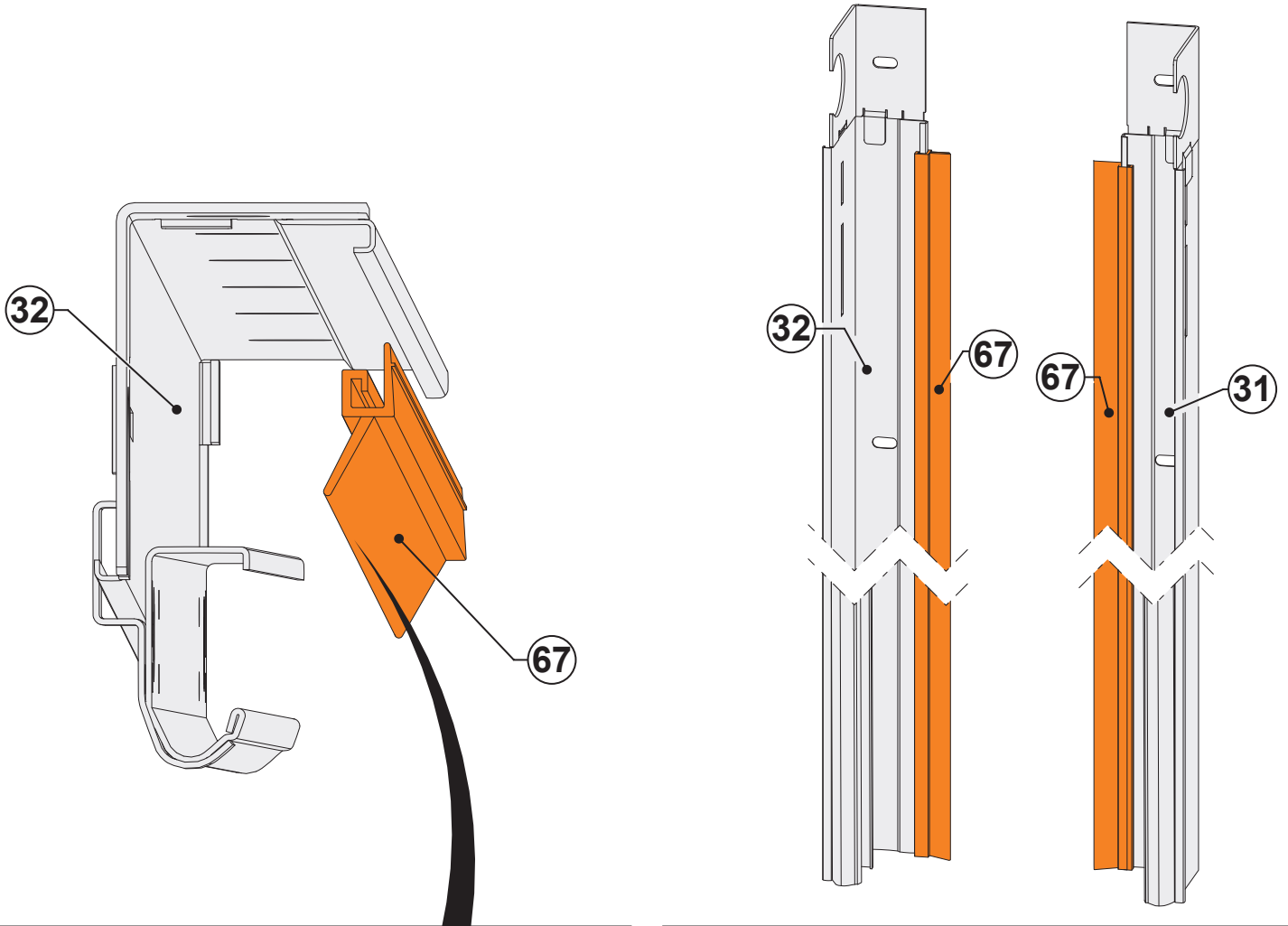
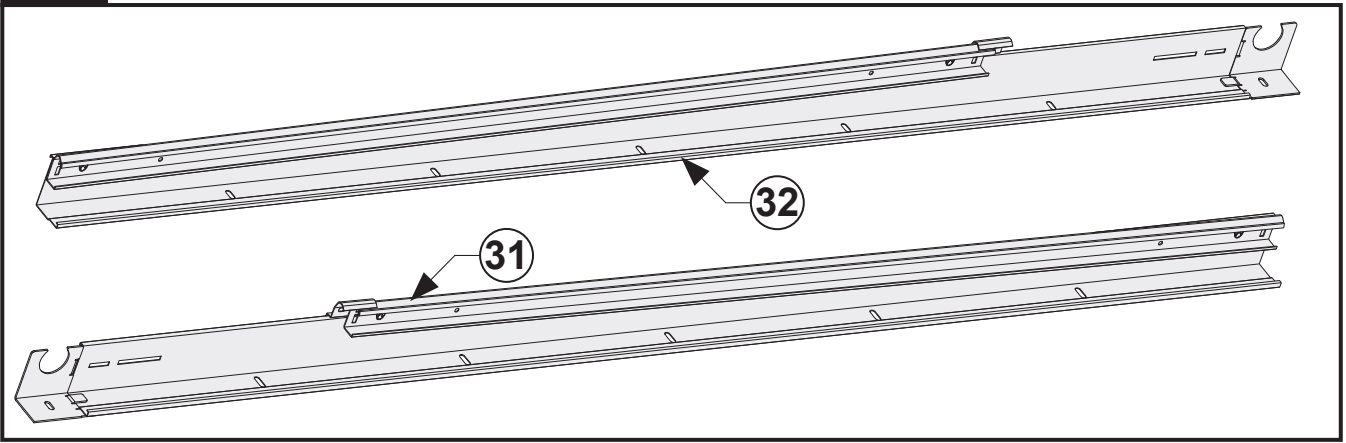



## 2.2 Fixation of the left vertical angle (32)

### 2.2.1 Mark the vertical angle position.

#### Tools

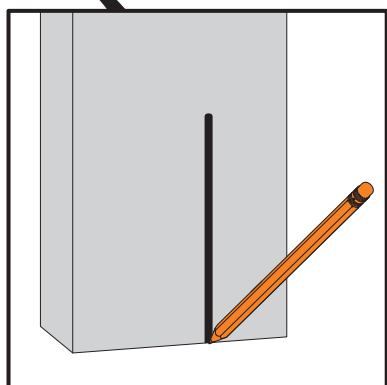
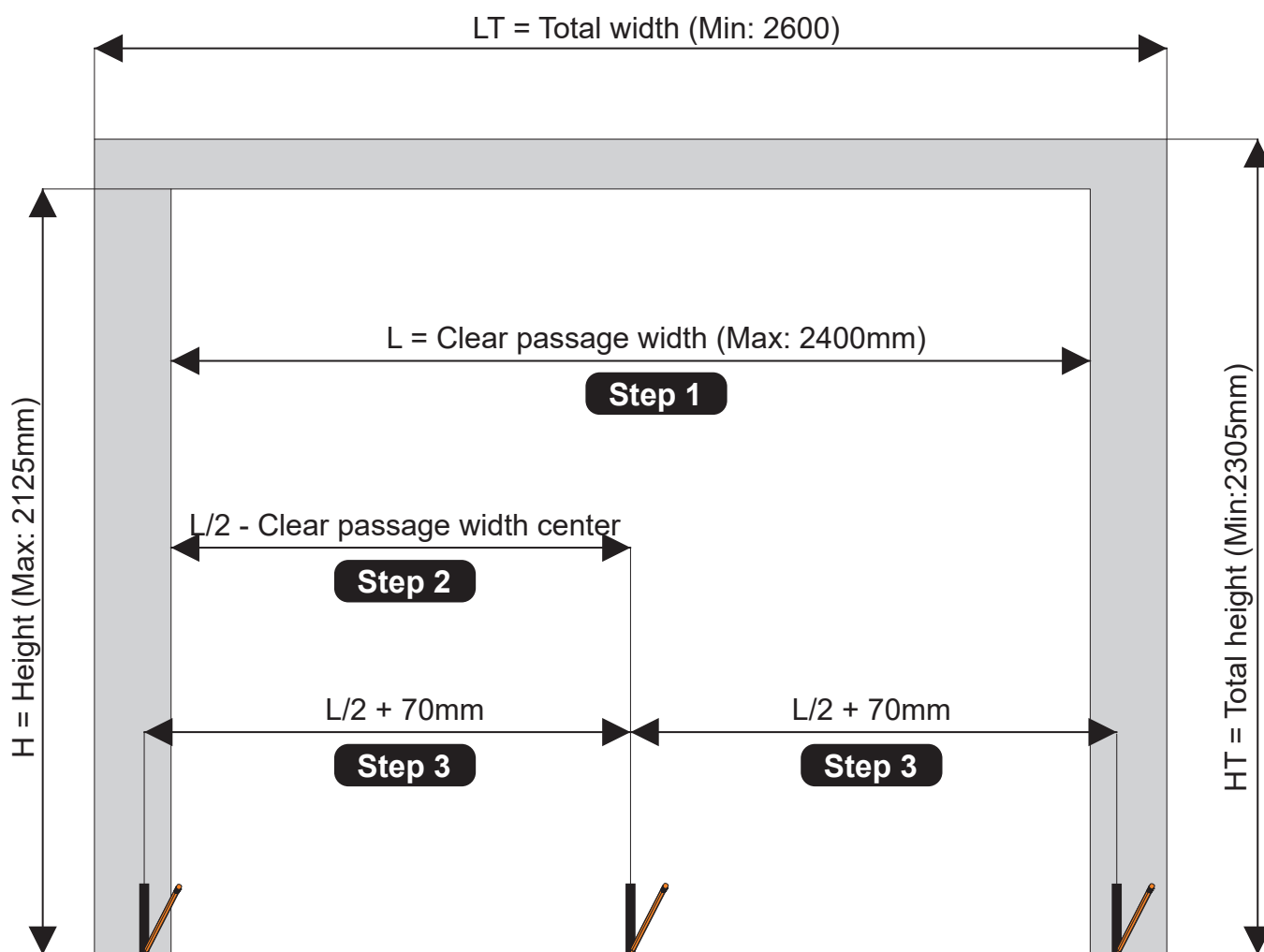
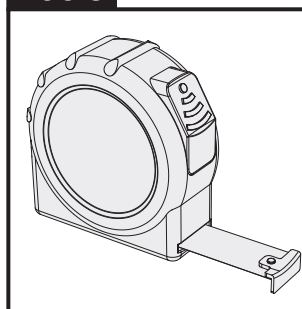

### Example

#### Step 1

If your clear passage width is:  
**L = 2400mm**

#### Step 2

Your clear passage width center is,  
 $L/2 = 2400/2 = 1200 \text{ mm}$   
and mark it on the floor.

#### Step 3

$L/2 + 70 = 1200 + 70 = 1270\text{mm}$

#### Step 4

And mark this measurement for each side from the center of the door.



To ensure that the impact force of the motor is in accordance with European standards in all measurement points, it is very important to ensure that the location where the door is to be installed is leveled and that the door installation is done in accordance with instructions.

## 2.2.2 Positioning the vertical angle (32).

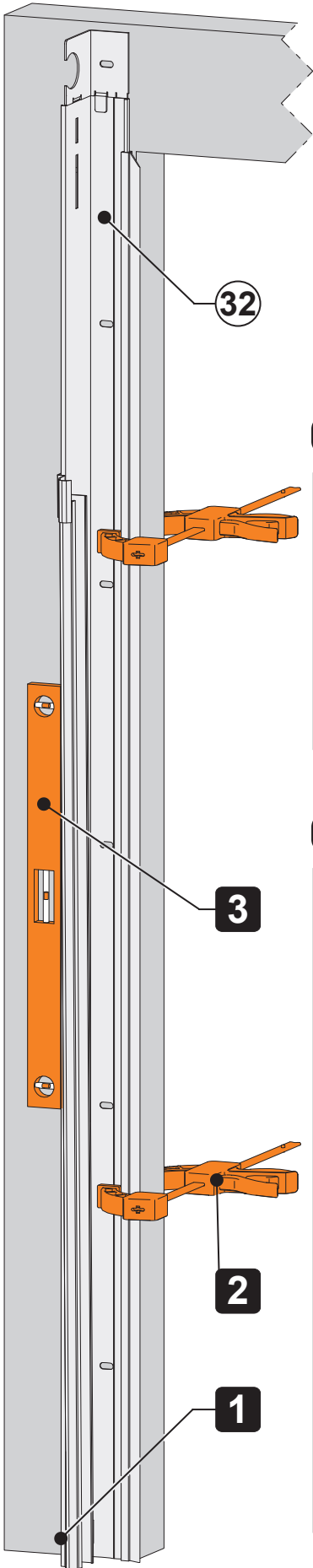

### Tools

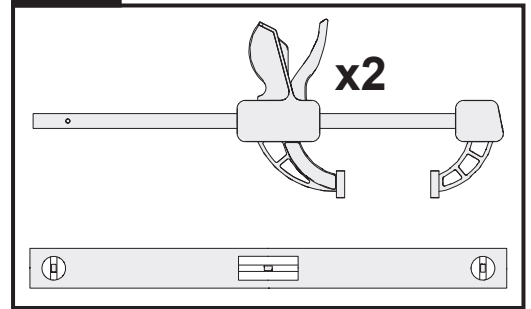

### Step 1

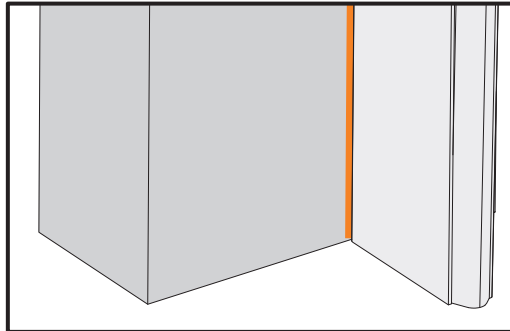

### Step 2

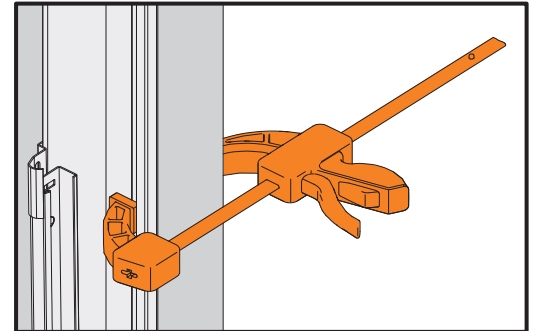

### Step 3

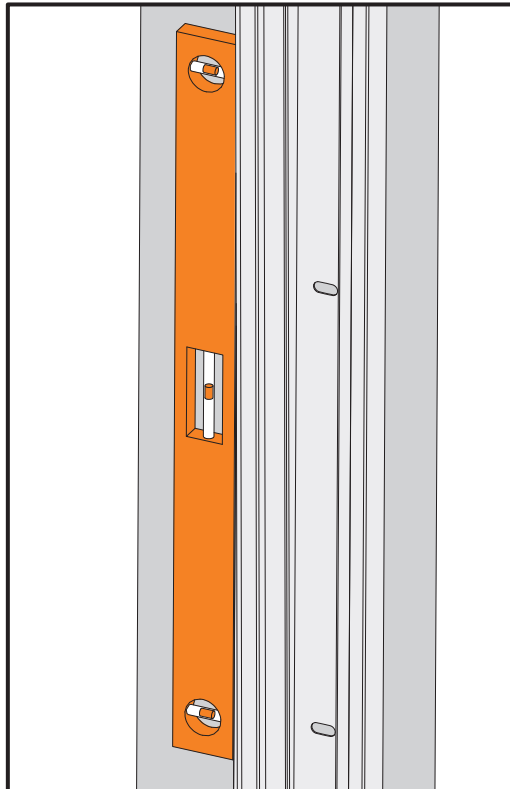

- 1 Positioning the vertical angle on the mark made in 2.2.1.
- 2 Positioning the vertical angle with the first clamp.
- 3 Check the vertical angle verticality and fix it with the second clamp.

### 2.2.3 Fixation of first vertical angle (32).

#### Tools

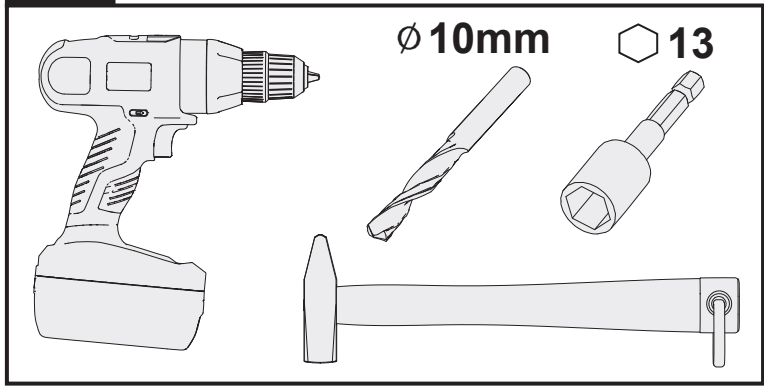

#### Parts

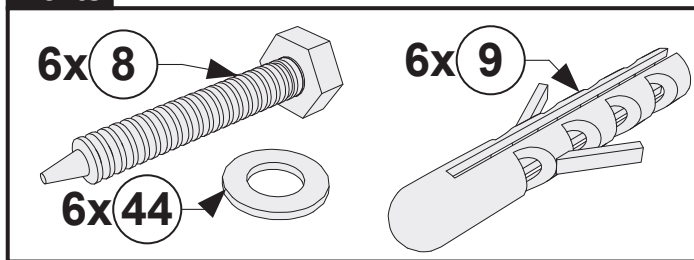

#### Step 1

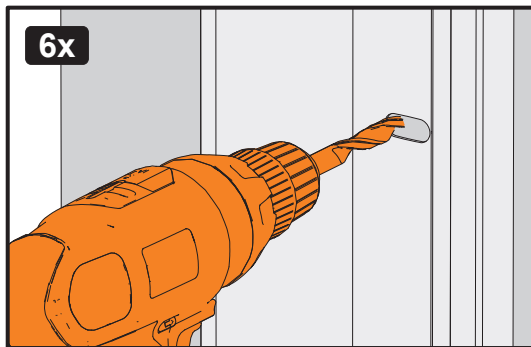

#### Step 2

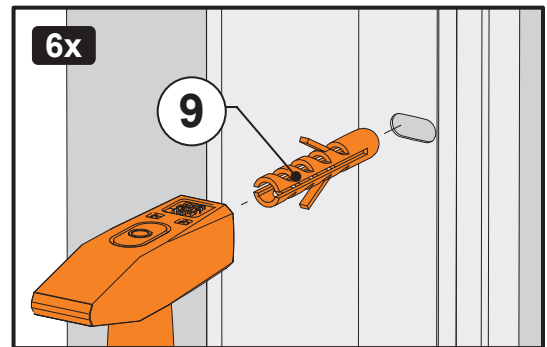

#### Step 3

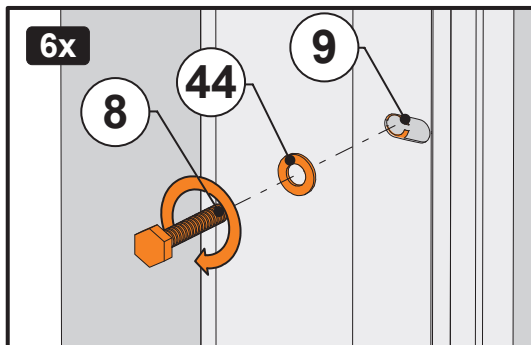

#### Step 4

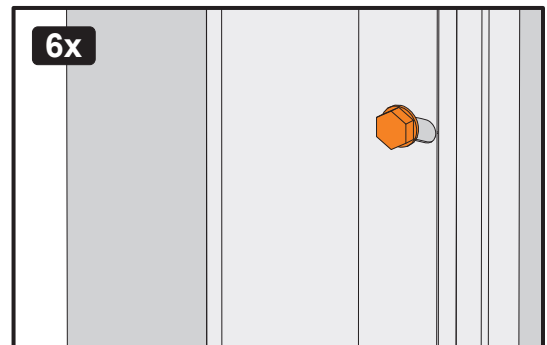

- 1 Drill the holes.
- 2 Positioning the nylon bushing (9).  
If necessary, remove the vertical angle to drill the holes and place the nylon bushing.  
In this case, you must repeat the operation of section 2.2.2 (steps 1, 2 and 3).
- 3 Screw the vertical angle with bolts (8) checking the verticality.
- 4 Placed first angle (32).

## 2.3 Fixation of second vertical angle (31)

2.3.1 Repeat steps 2.2.2 to 2.2.3 to fix the second vertical angle(31).

### Tools

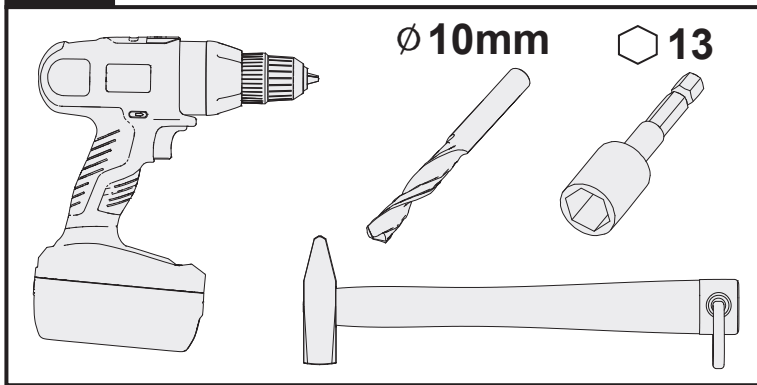

### Parts

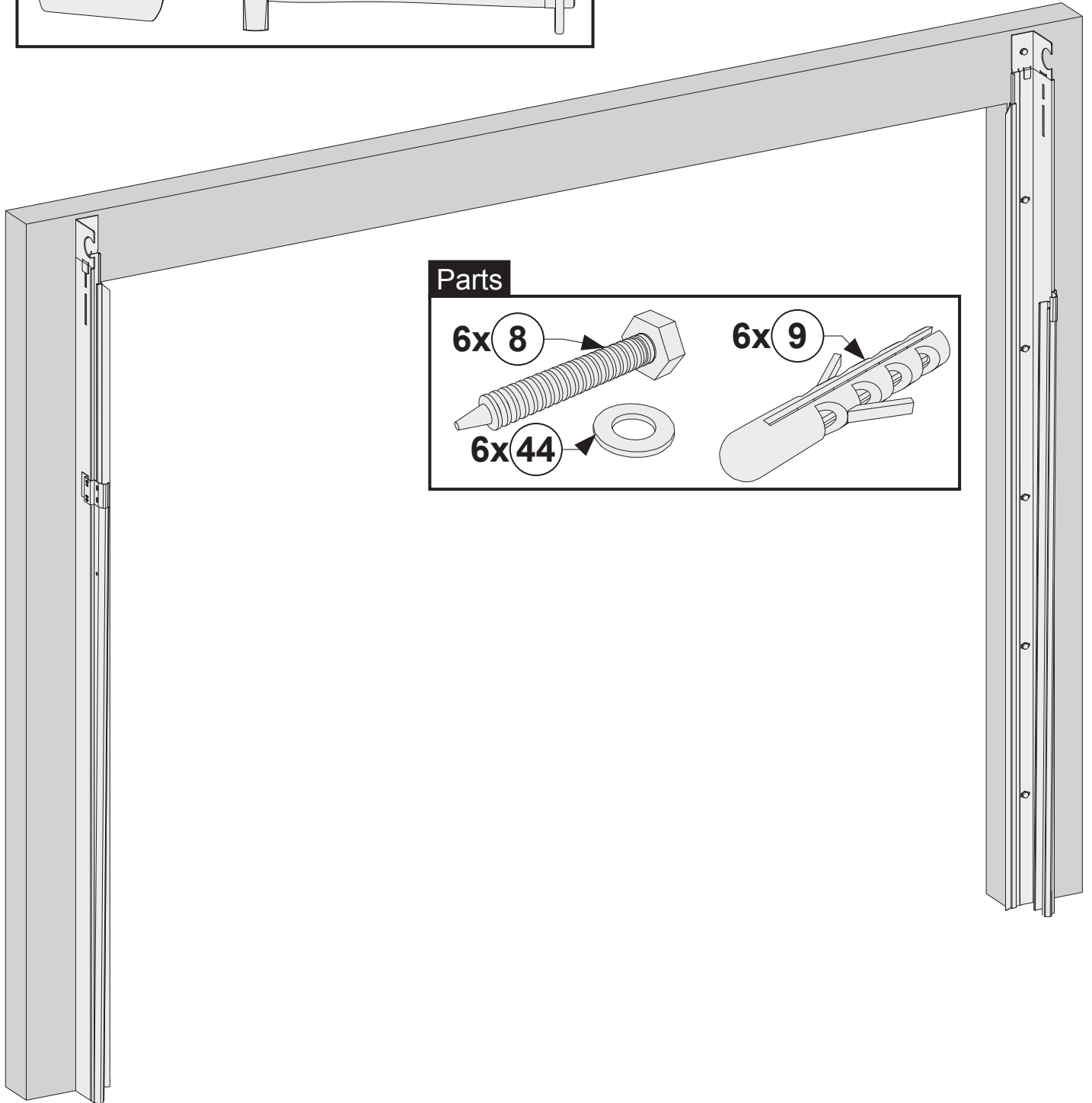
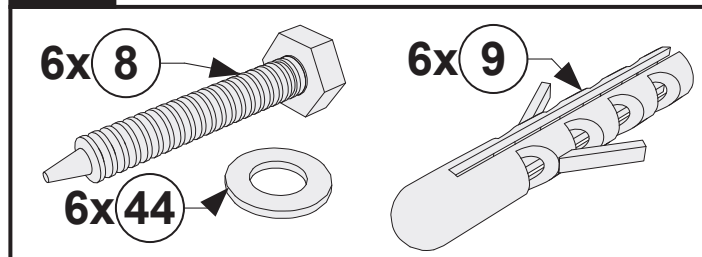

## 2.4 Top profile assembly

2.4.1 Cut the ends of rubber seal (61) at 45 degrees with a cutter.

### Tools

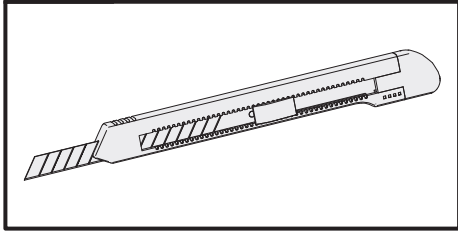

### Parts

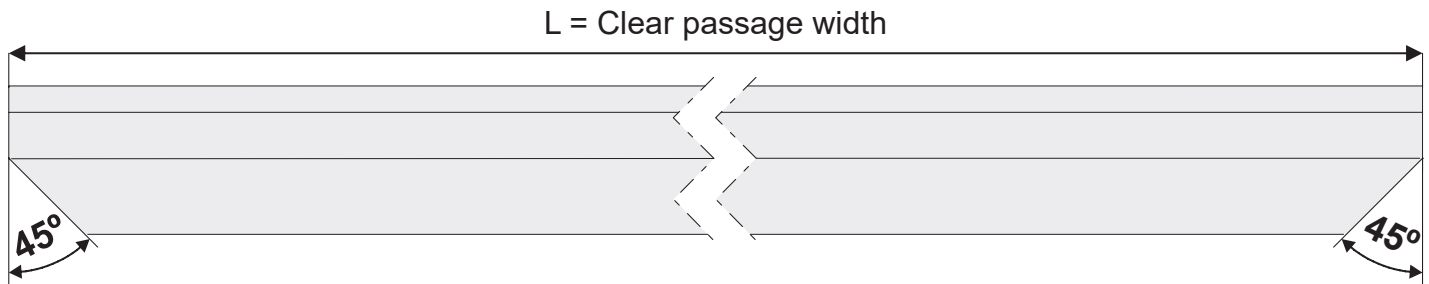
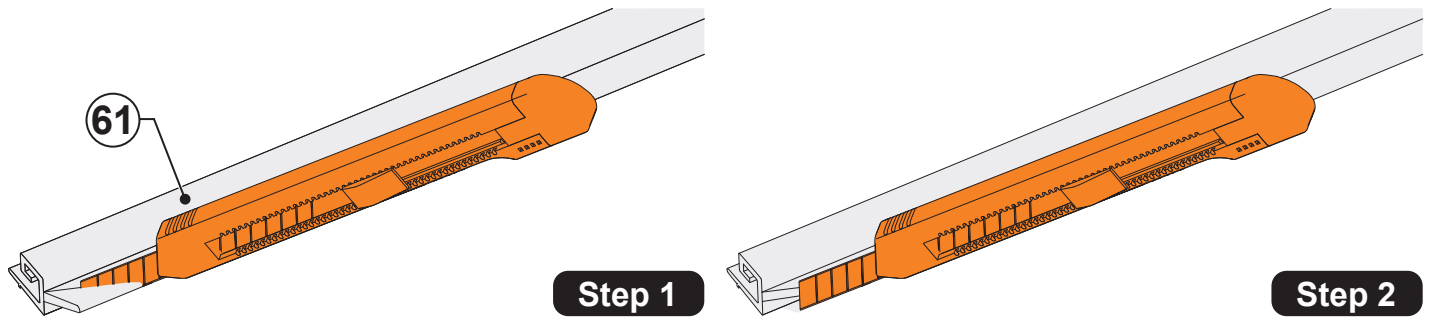
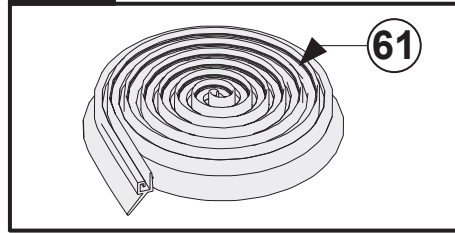

2.4.2 Mounting the top rubber seal (61) on the the top profile (60).

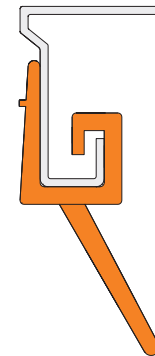
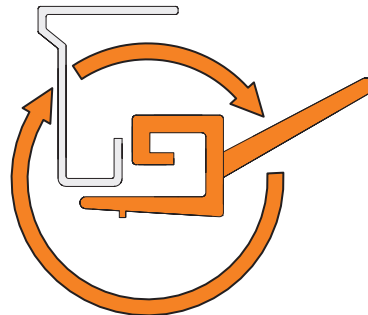
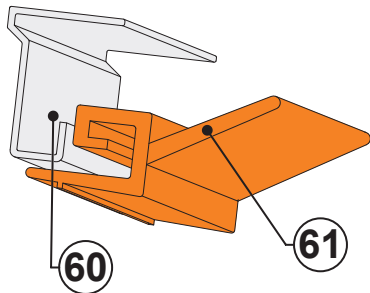

## 2.5 Fixation the top profile (60)

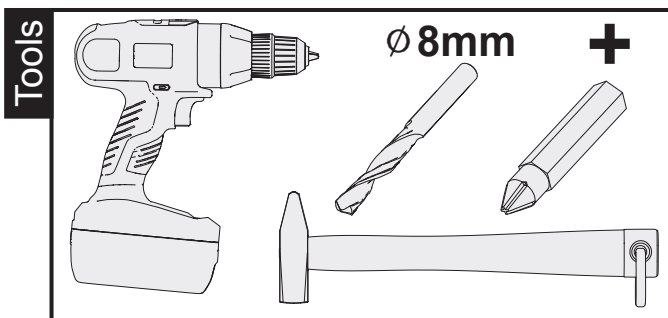
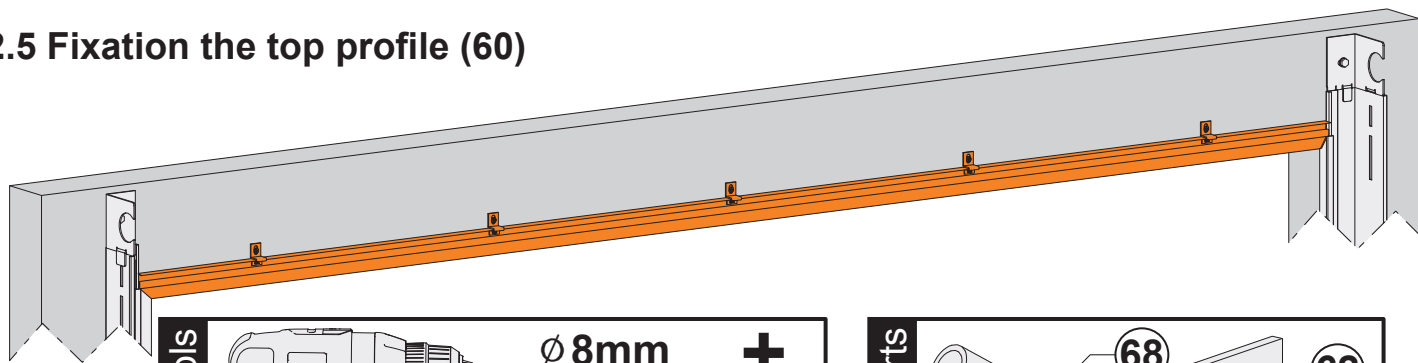

**Step 1**

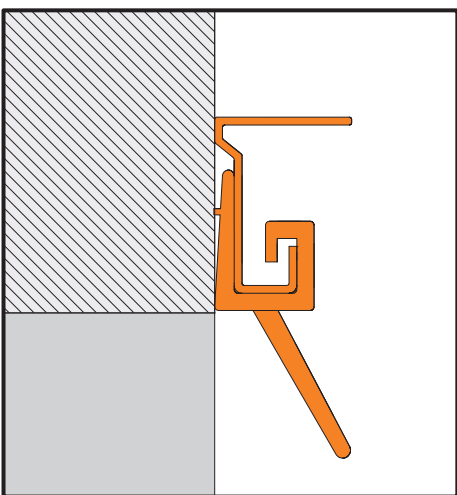

**Step 2**

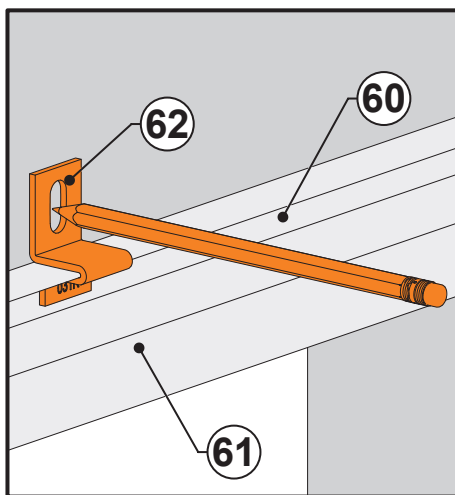

**Step 3**

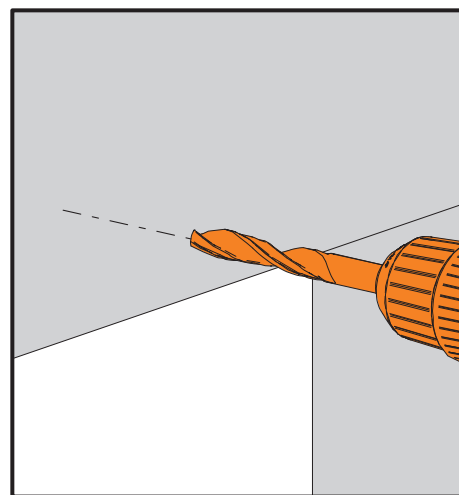

**Step 4**

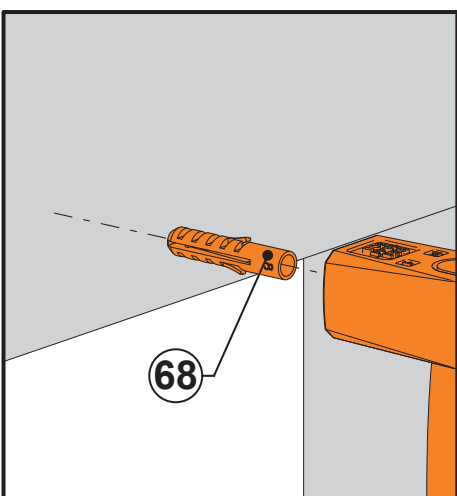

**Step 5**

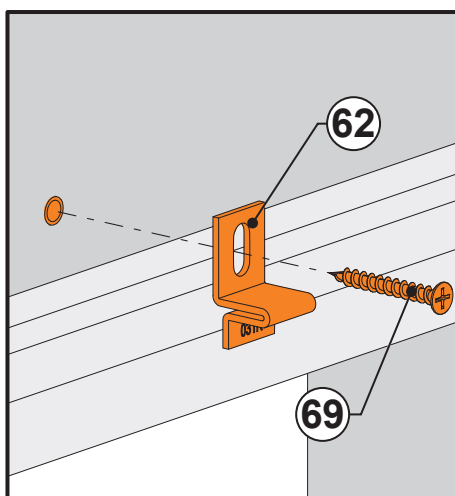

**Step 6**

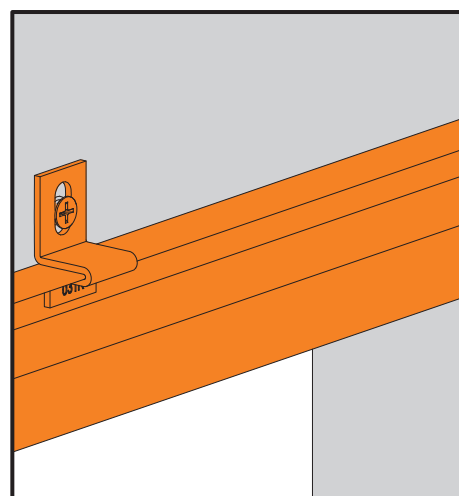

- 1** Positioning the top profile (60).
- 2** Mark the holes locations of the parts (62).
- 3** Drill the holes.
- 4** Positioning the nylon bushing (68).
- 5** Screw the parts (62) with bolts (69).
- 6** Placed top profile (60).

## 2.6 Fixation of the horizontal tracks to the vertical angles

2.6.1 Screw with the bolts (6 and 10) and nuts (11), the horizontal track (27) to the vertical angle (32).

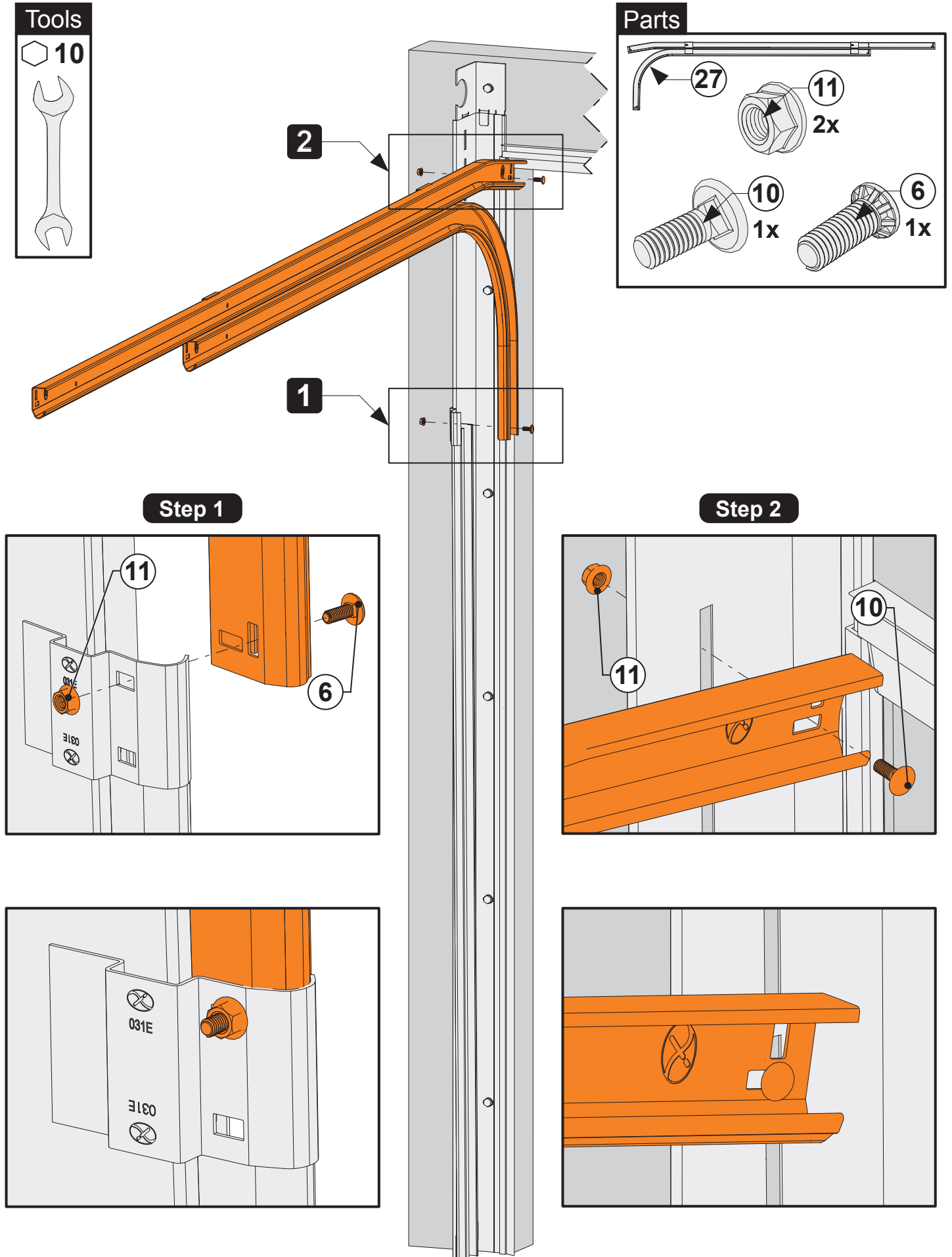

### 2.6.2 Check the horizontality of the track.

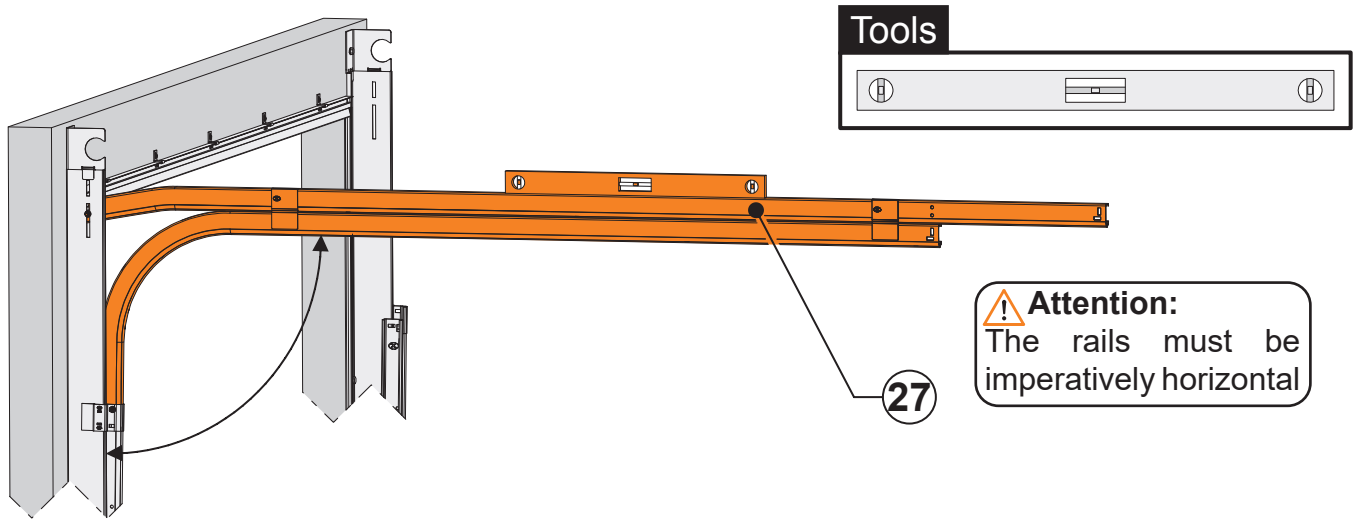

### 2.6.3 Repeat steps 2.6.1 to 2.6.2 to fix the second track (26).

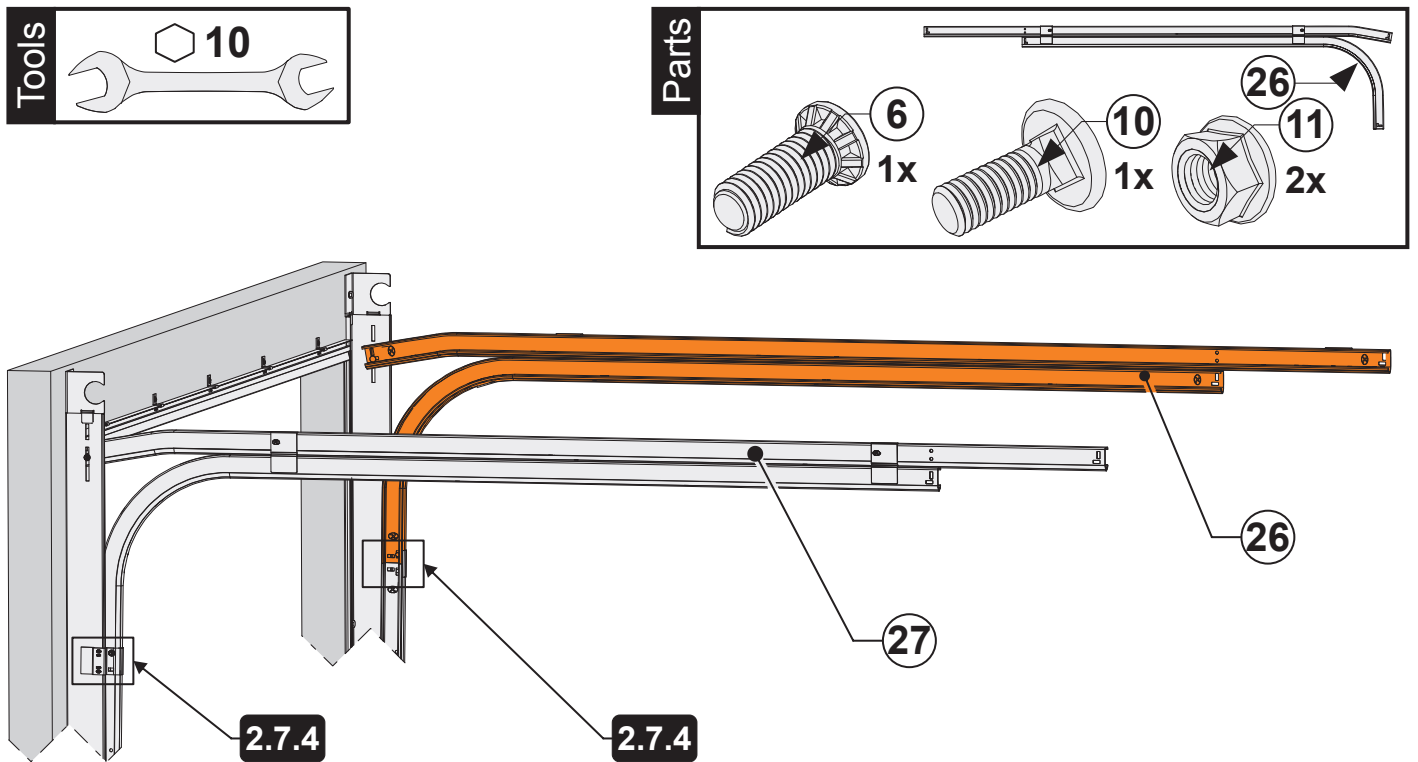

### 2.7.4 Align the vertical angle (31 and 32) joint with the horizontal track (26 and 27) with a Locking Pliers, so that the roller has smooth movement at the joint.

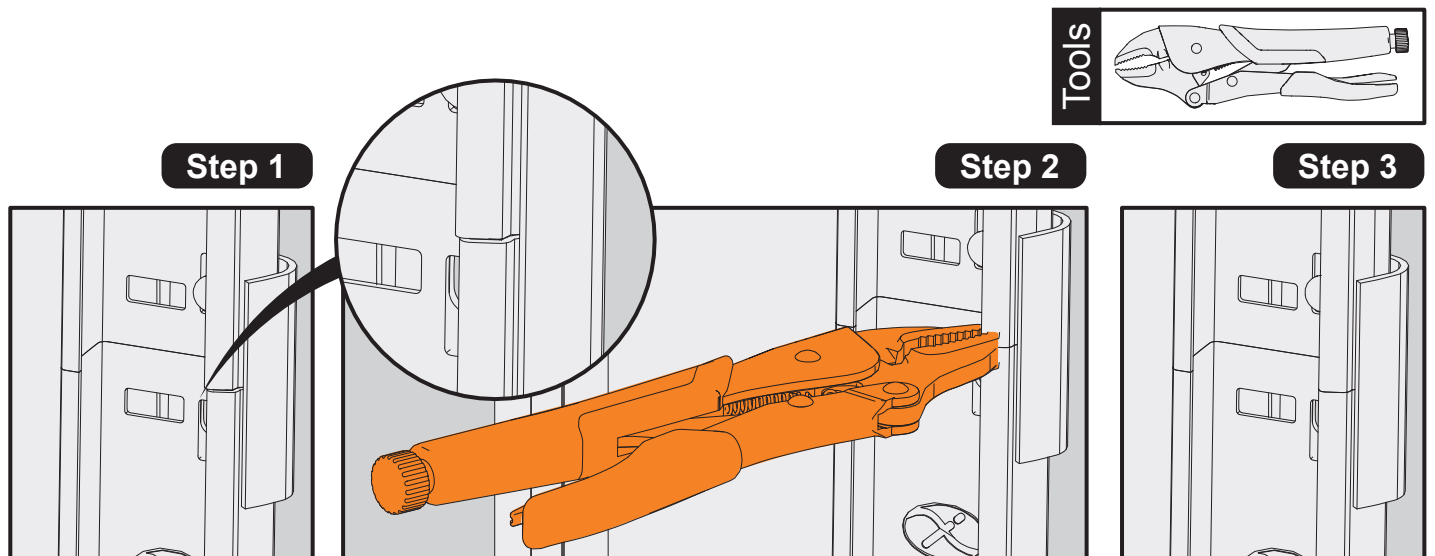



## 2.7 Fixation of the horizontal tracks to the ceiling

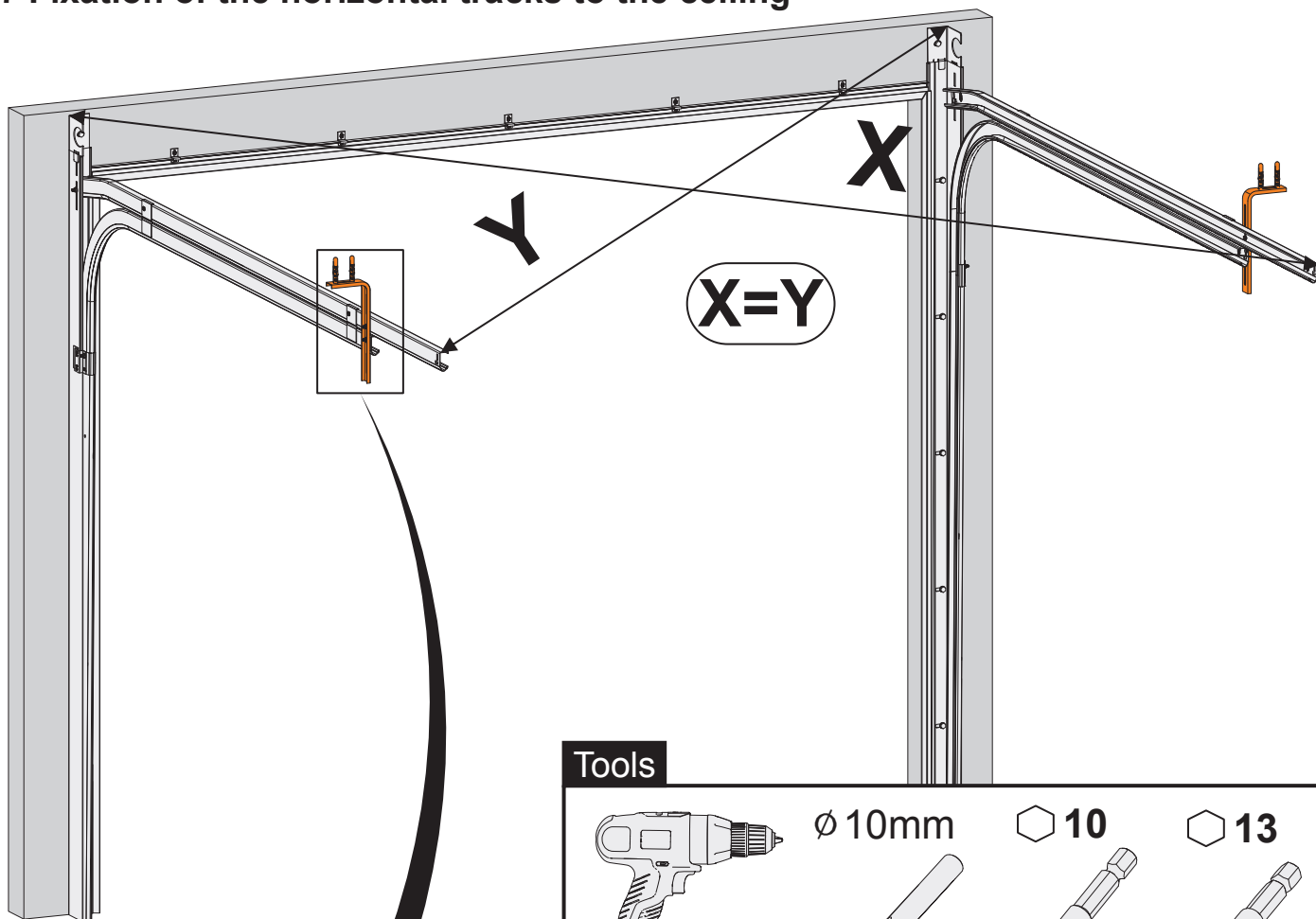

### Tools

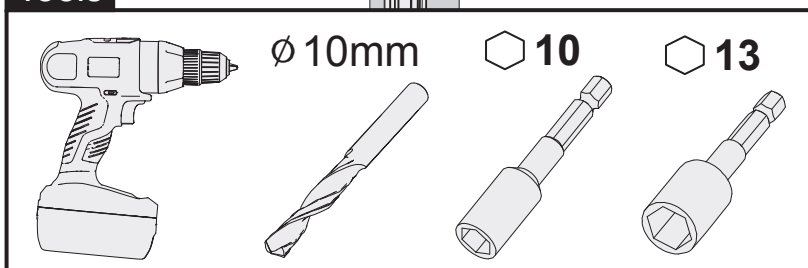

### Parts

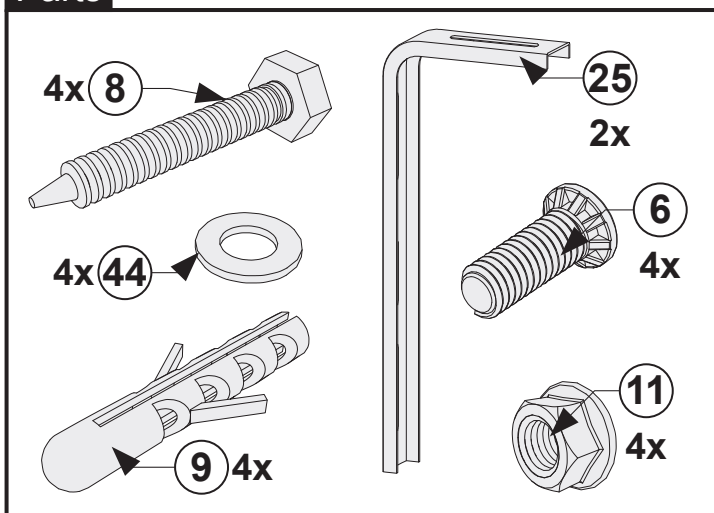

- 1 Verify that the horizontal tracks diagonals lengths are equal:  $X = Y$ .
- 2 Fix the suspensions (25) to the horizontal tracks (26 and 27) using the bolts (6) and nuts (11).
- 3 Mark the location of the drill holes in the ceiling.
- 4 Drill the ceiling and place the nylon bushings (9).
- 5 Fix the suspensions (25) to the ceiling with bolts (8) and washers (44).



Never use as a fixing system belts, ropes and other elastic or flexible supports!

### 3. Shaft and springs assembly



Place the cable drums in the shaft (cable drum painted in red on the left side and the other painted in black on the right side), and place the shaft assembly in a proper position to be mounted on the door.

#### 3.1 Shaft assembly

3.1.1 Insert the different components on the shaft according to the order of the scheme.

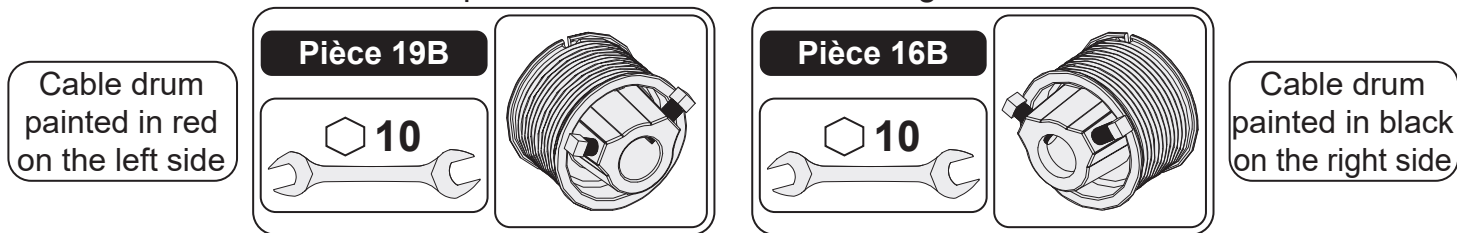

#### Shaft (left side)

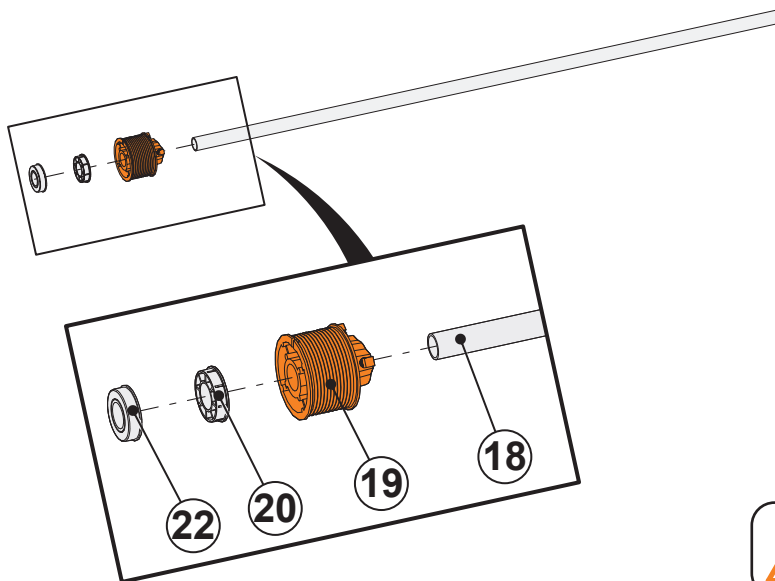

$18 < 46$

#### Shaft (right side)

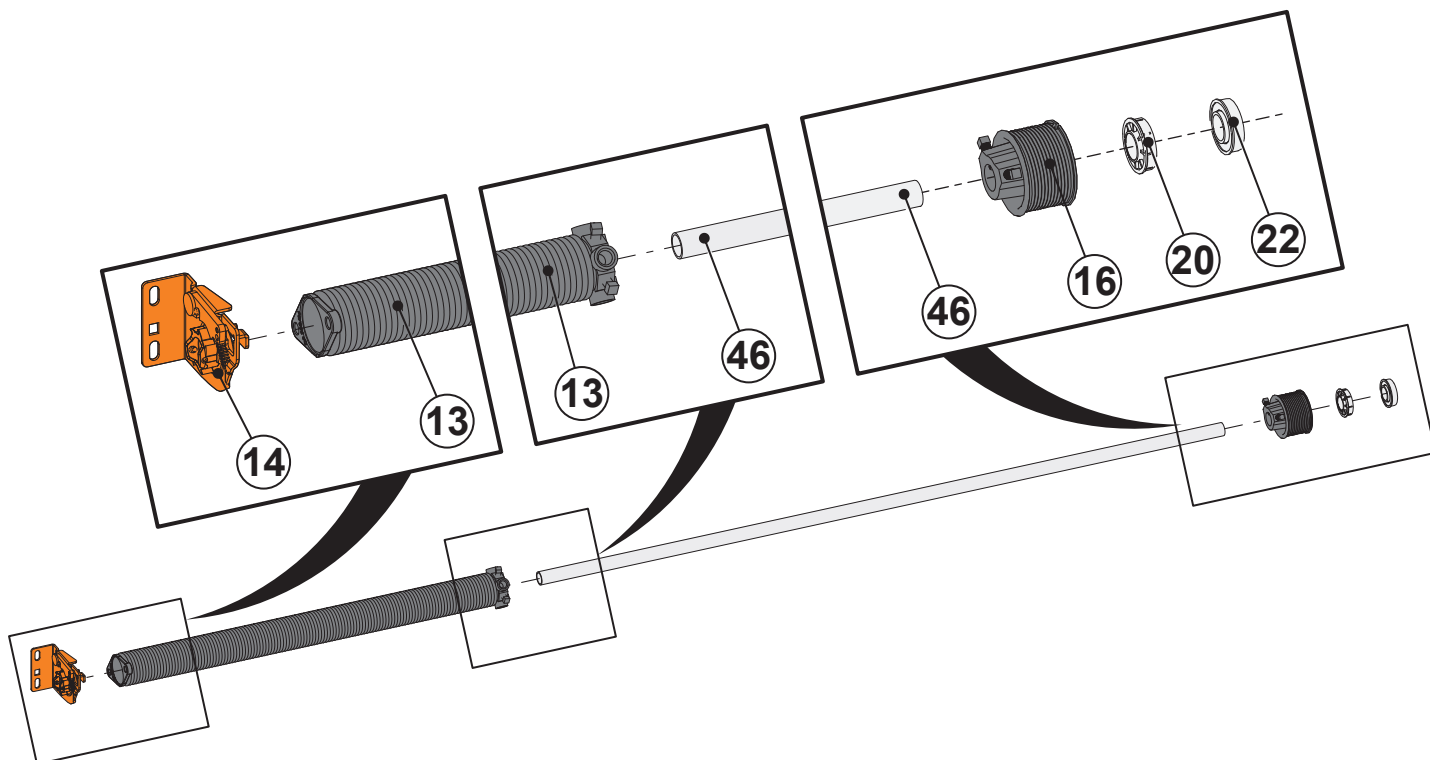

3.1.2 Assemble the shafts (18) and (46) with the coupling (38).

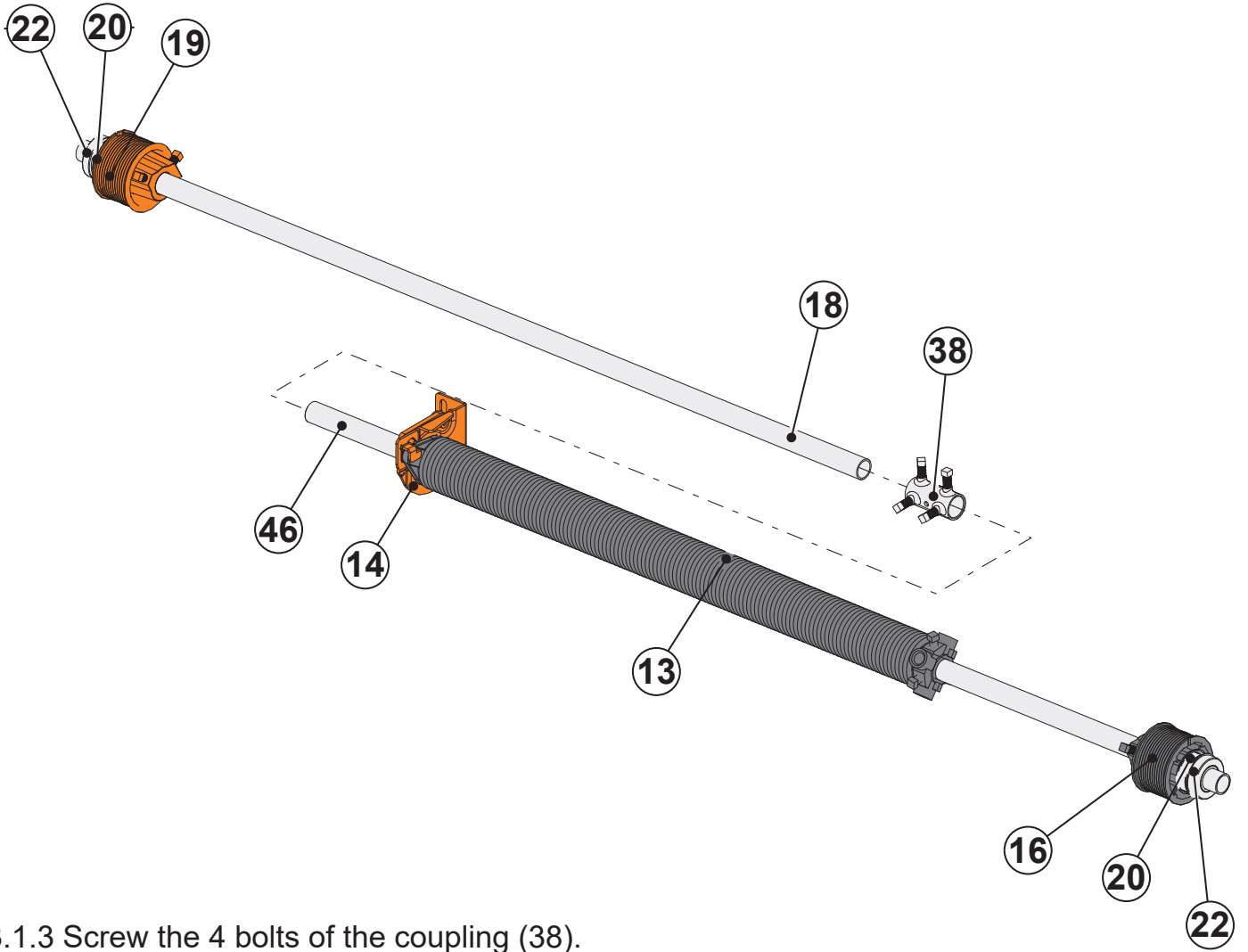

3.1.3 Screw the 4 bolts of the coupling (38).

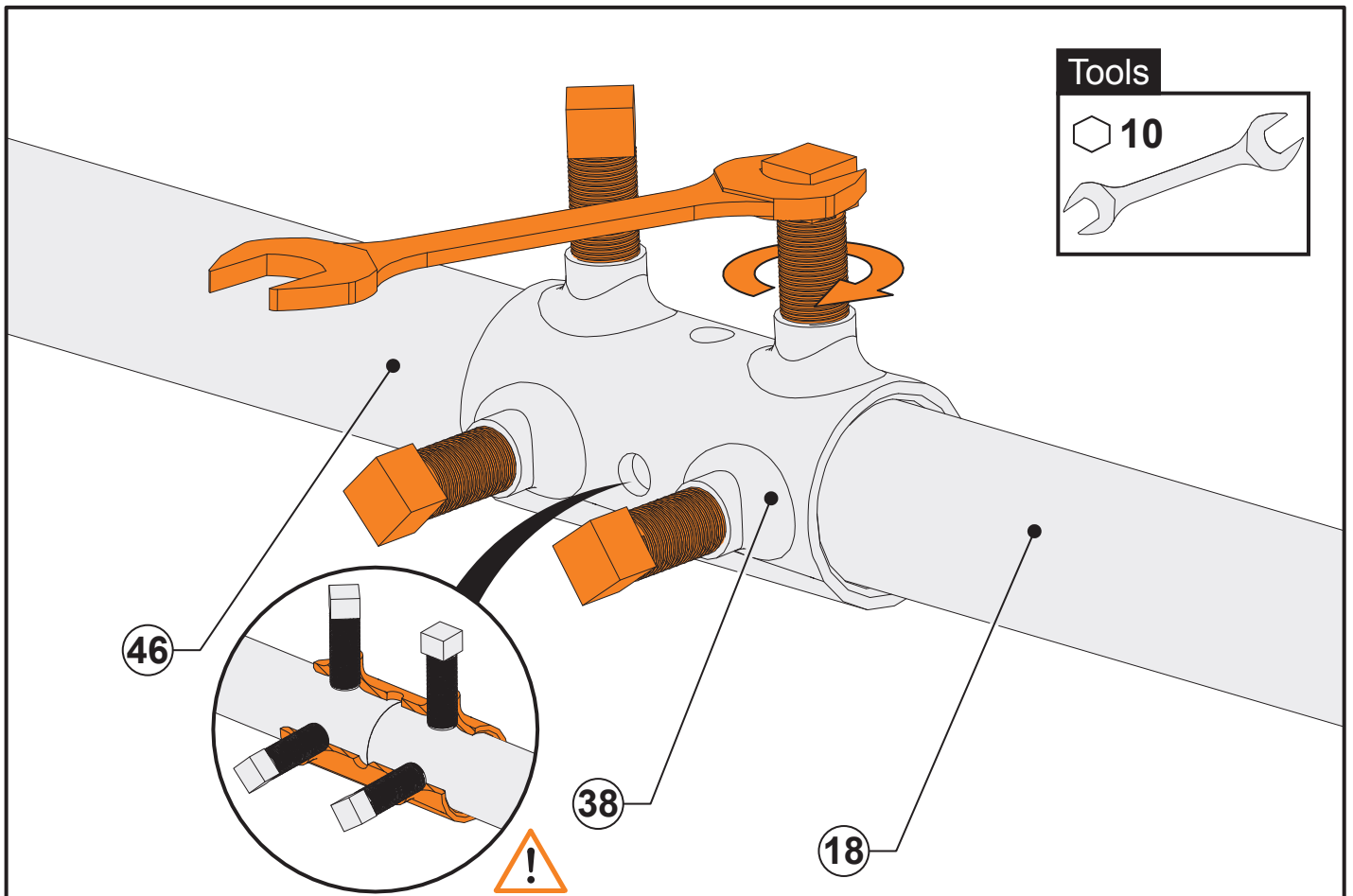

## 3.2 Fixing the shaft to the vertical angles

### 3.2.1 Position the shaft in the vertical angles.

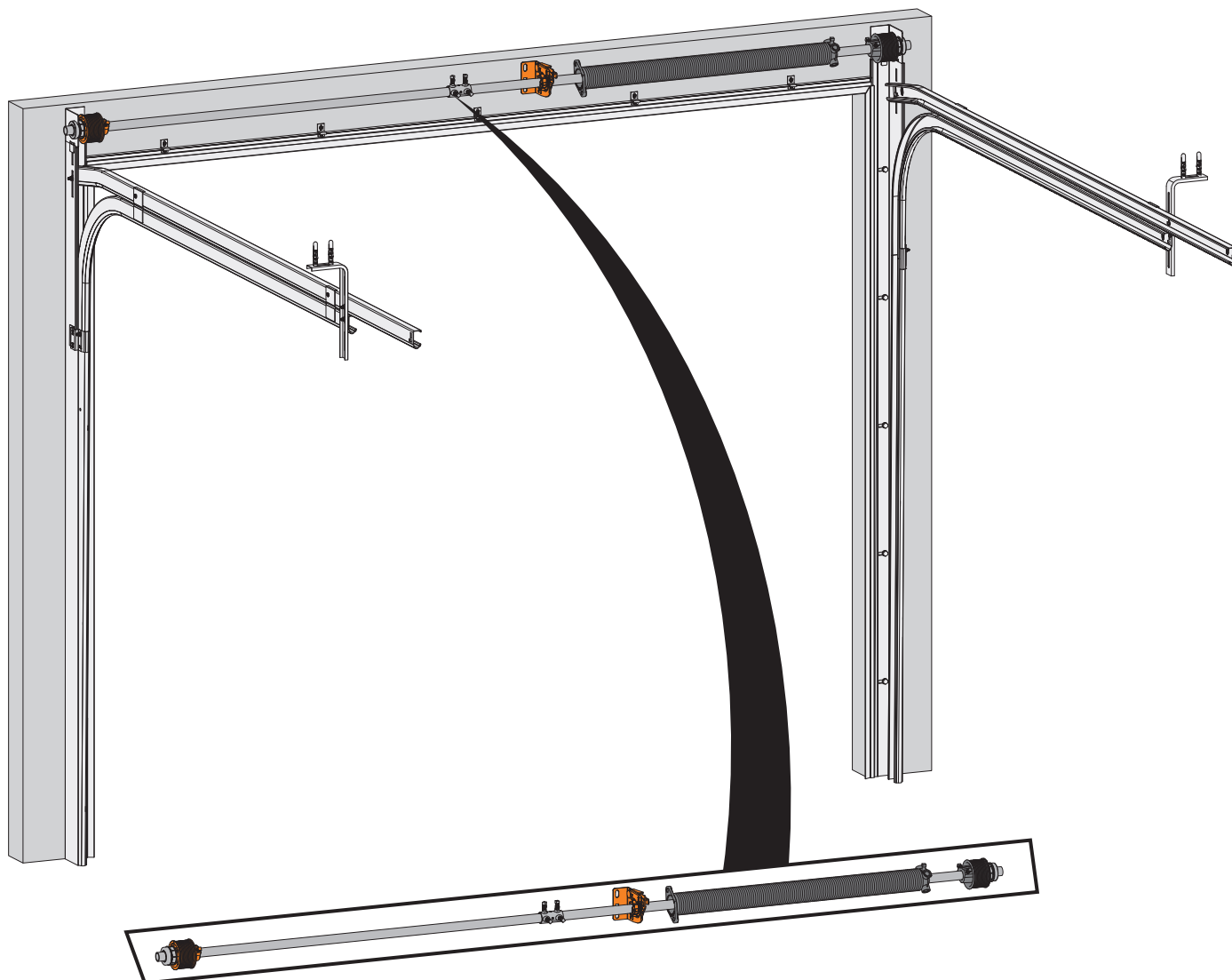

3.2.2 Move the bearings (22) against the vertical angles (31) and (32).

**Left side**

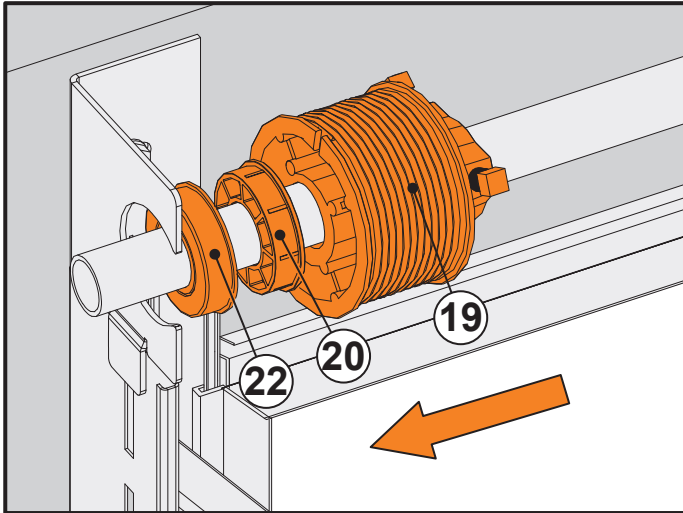

**Right side**

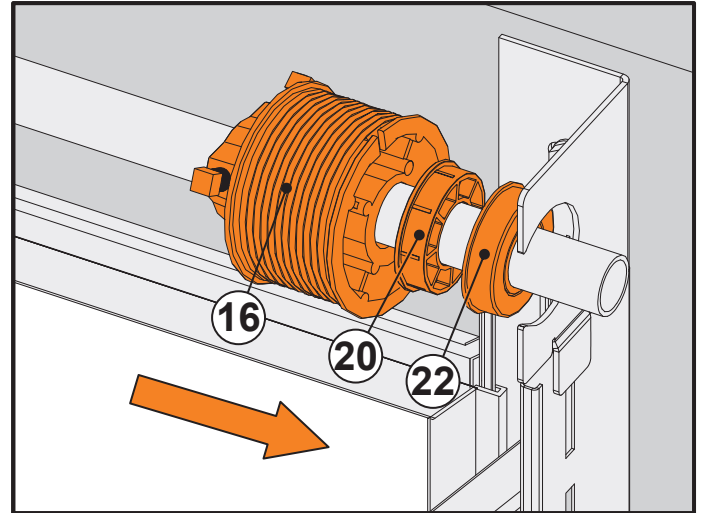

3.2.3 Push the PVC bearing (20) against the metal bearing (22).

**Left side**

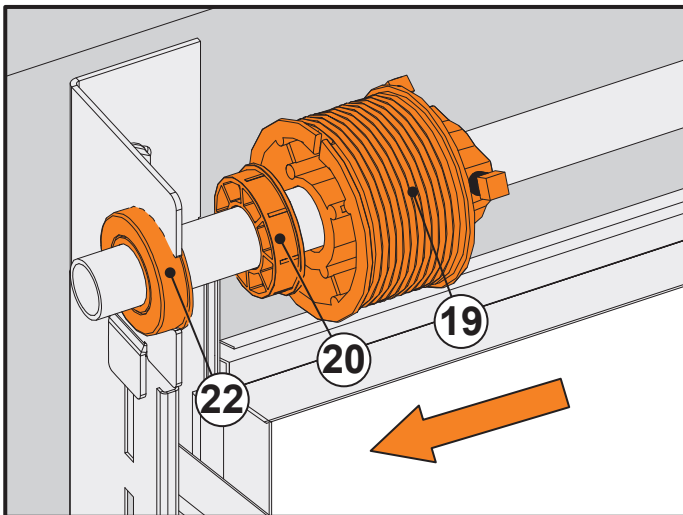

**Right side**

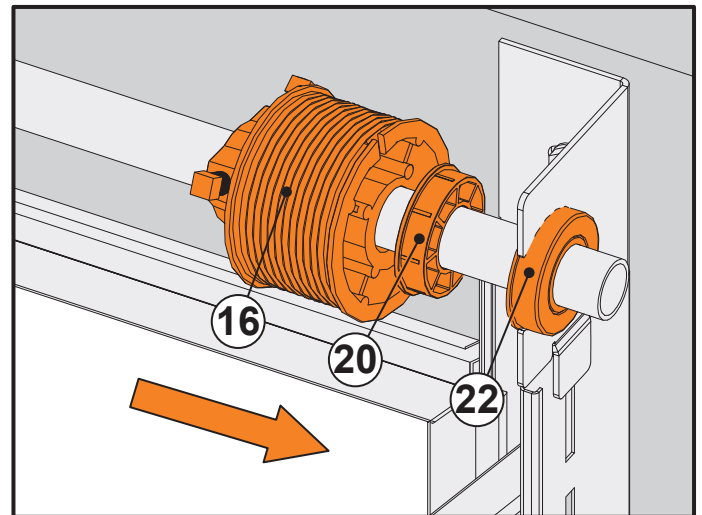

3.2.4 Place the cable drums against the PVC bearings (20).

**Left side**

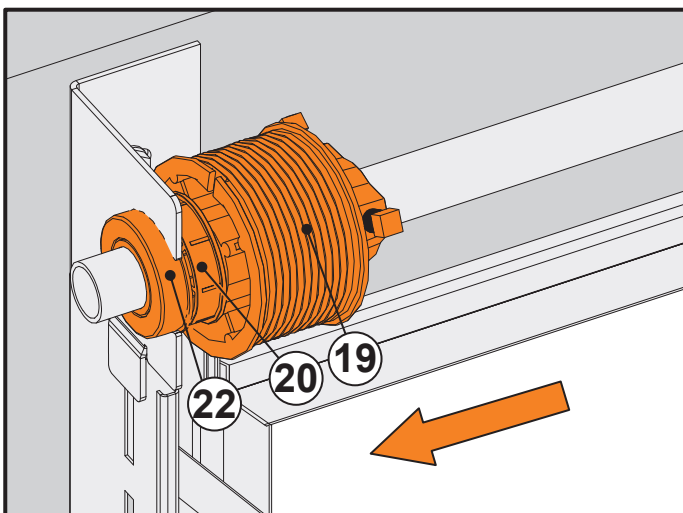

**Right side**

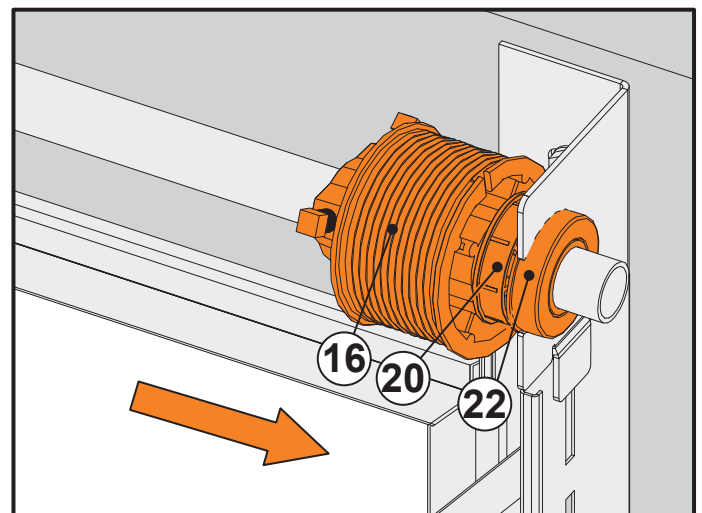

### 3.3 Fixation of the shaft in the headroom

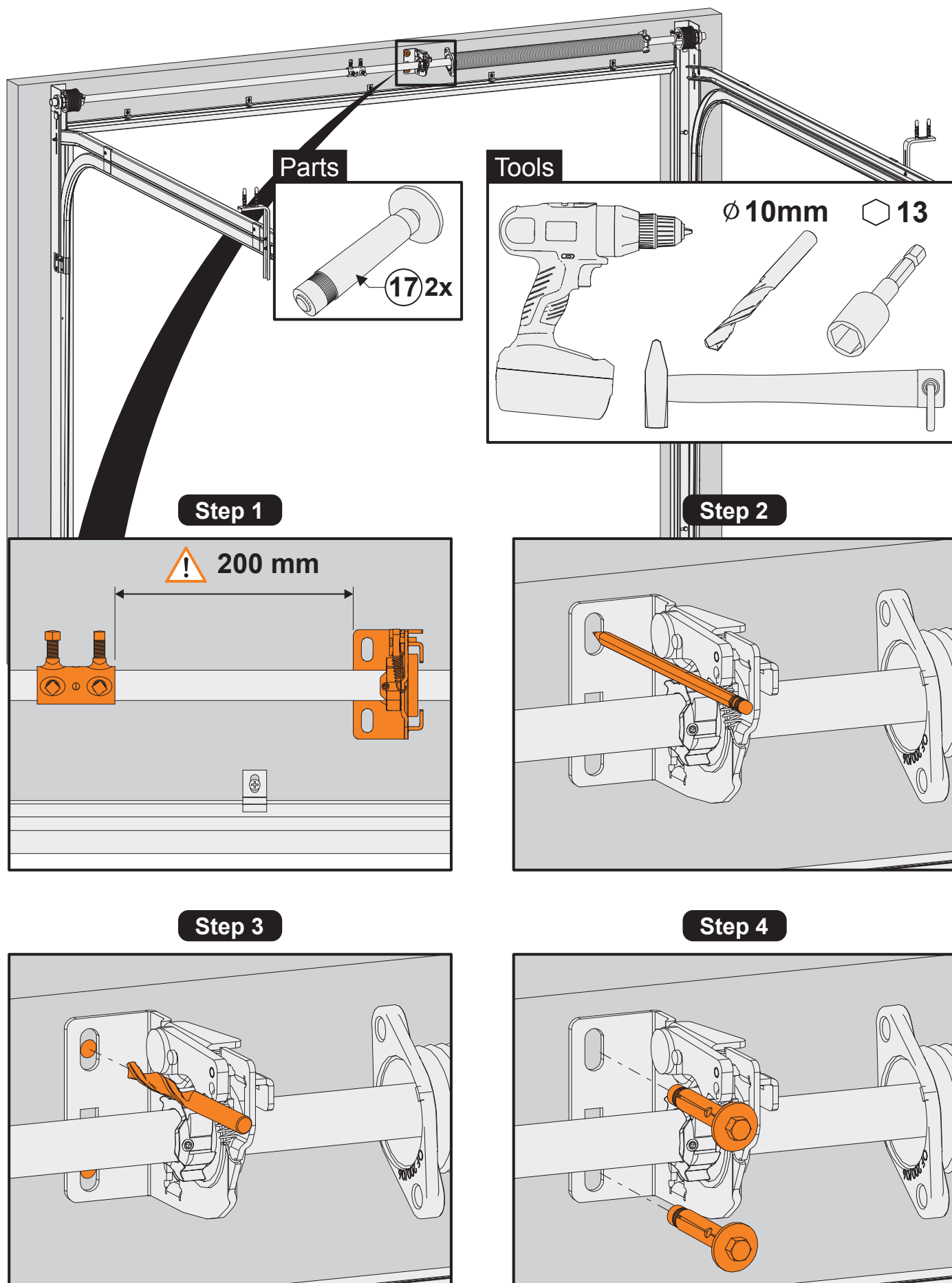

- 1 Positioning the right spring break device (14), the coupling (38) so that they are spaced 200mm.
- 2 Mark the holes locations.
- 3 Drill two holes Ø10.
- 4 Fix the spring break devices (14) in the headroom, using the metal plugs (17).

### 3.4 Installation of the spring break device

#### 3.4.1 Fixation the spring break device (14) on the shaft.

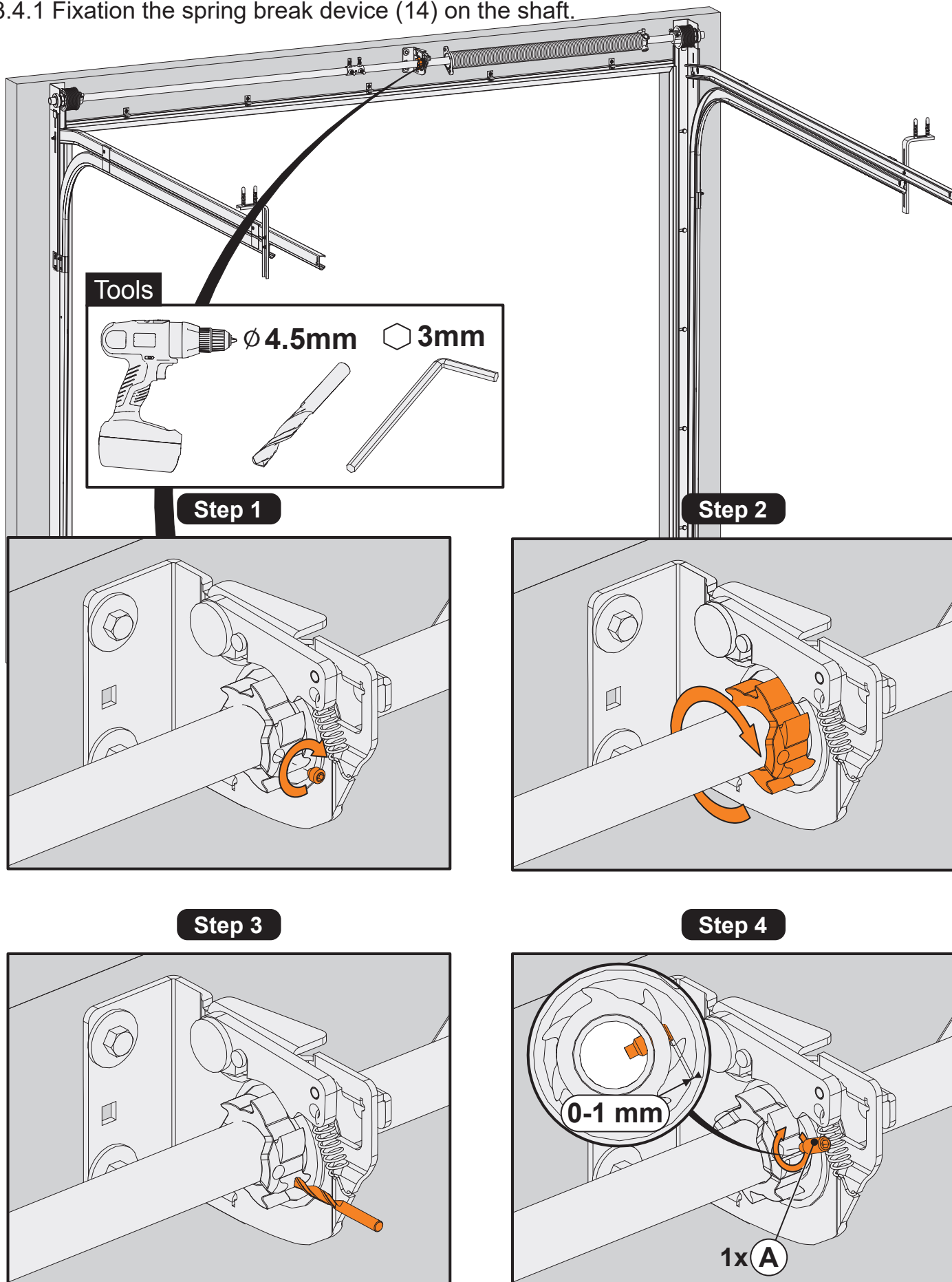

- 1 Screw the spring break device bolt on the shaft.
- 2 Rotate the shaft by 180 degrees.
- 3 Drill the shaft (6mm diameter drill) facing the hole on the spring break device.
- 4 Screw the bolt (A) in the hole. The bolt is in the spring break device bag (14).

### 3.4.2 Positioning the spring.

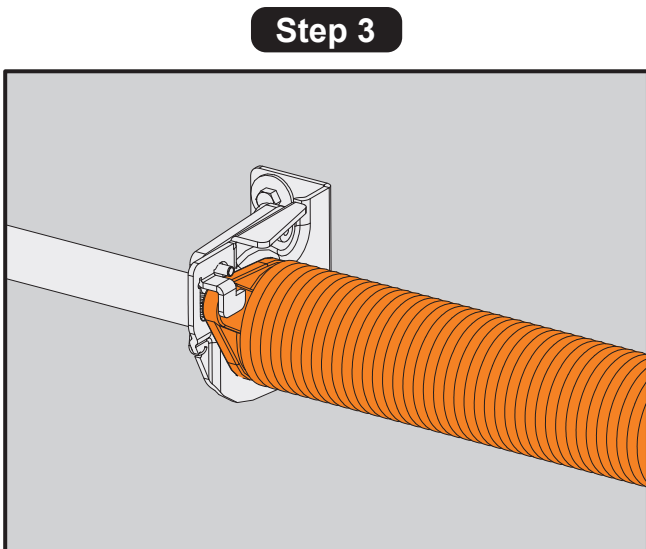
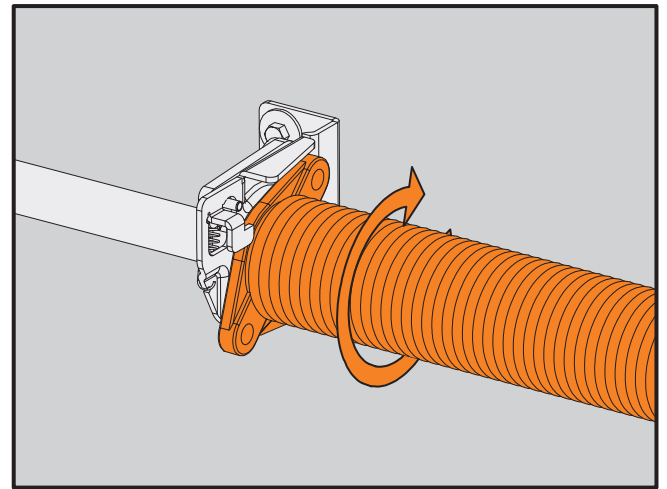
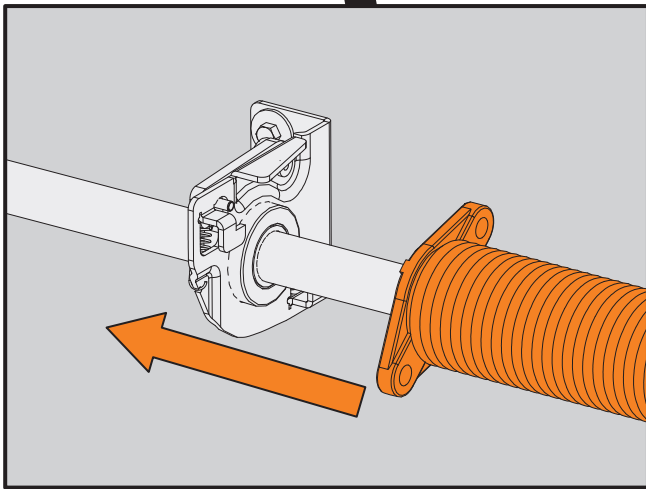
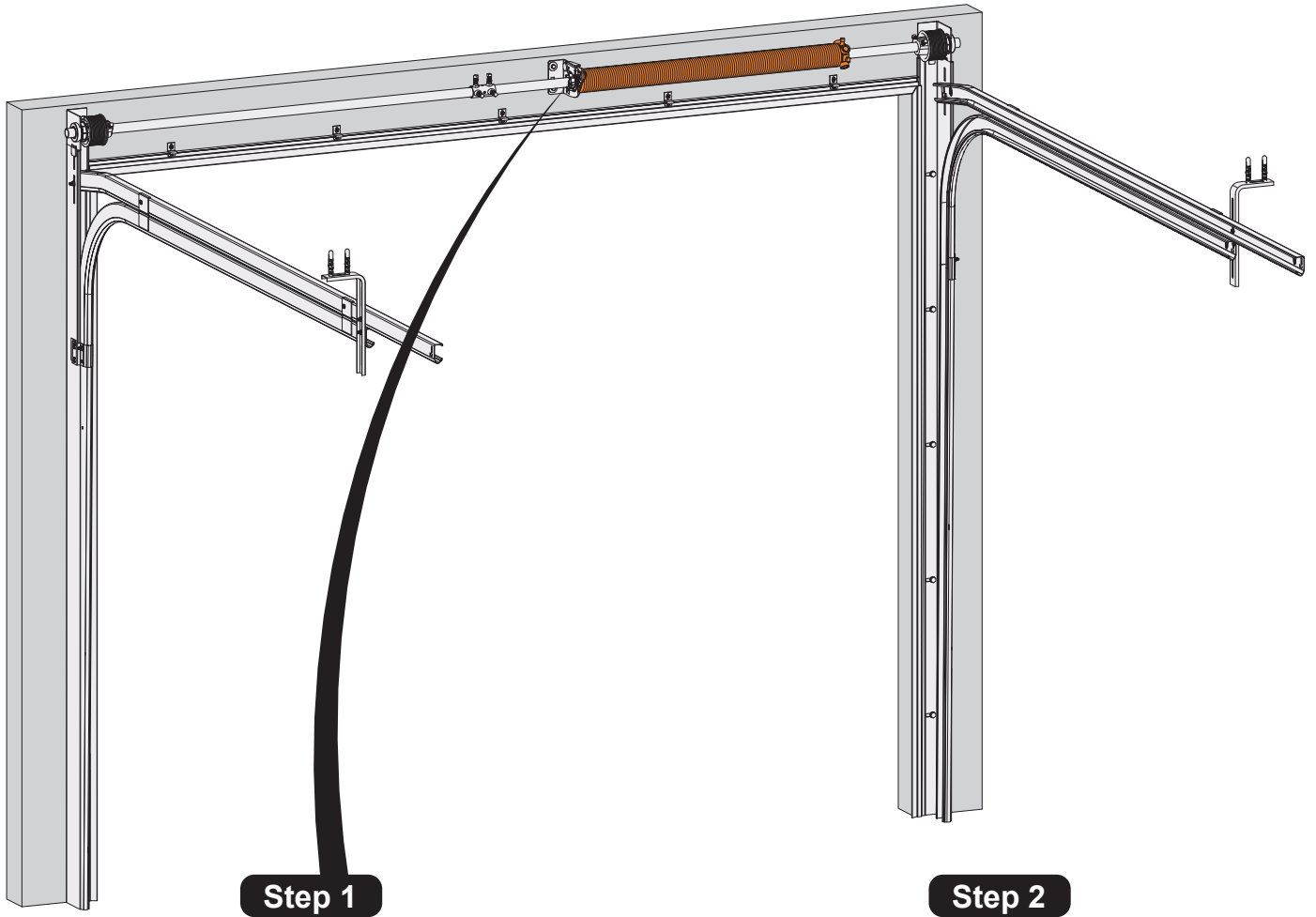



## 4. Door panels assembly

### 4.1 Bottom panel assembly

4.4.1 Place the bottom panel (35-1).

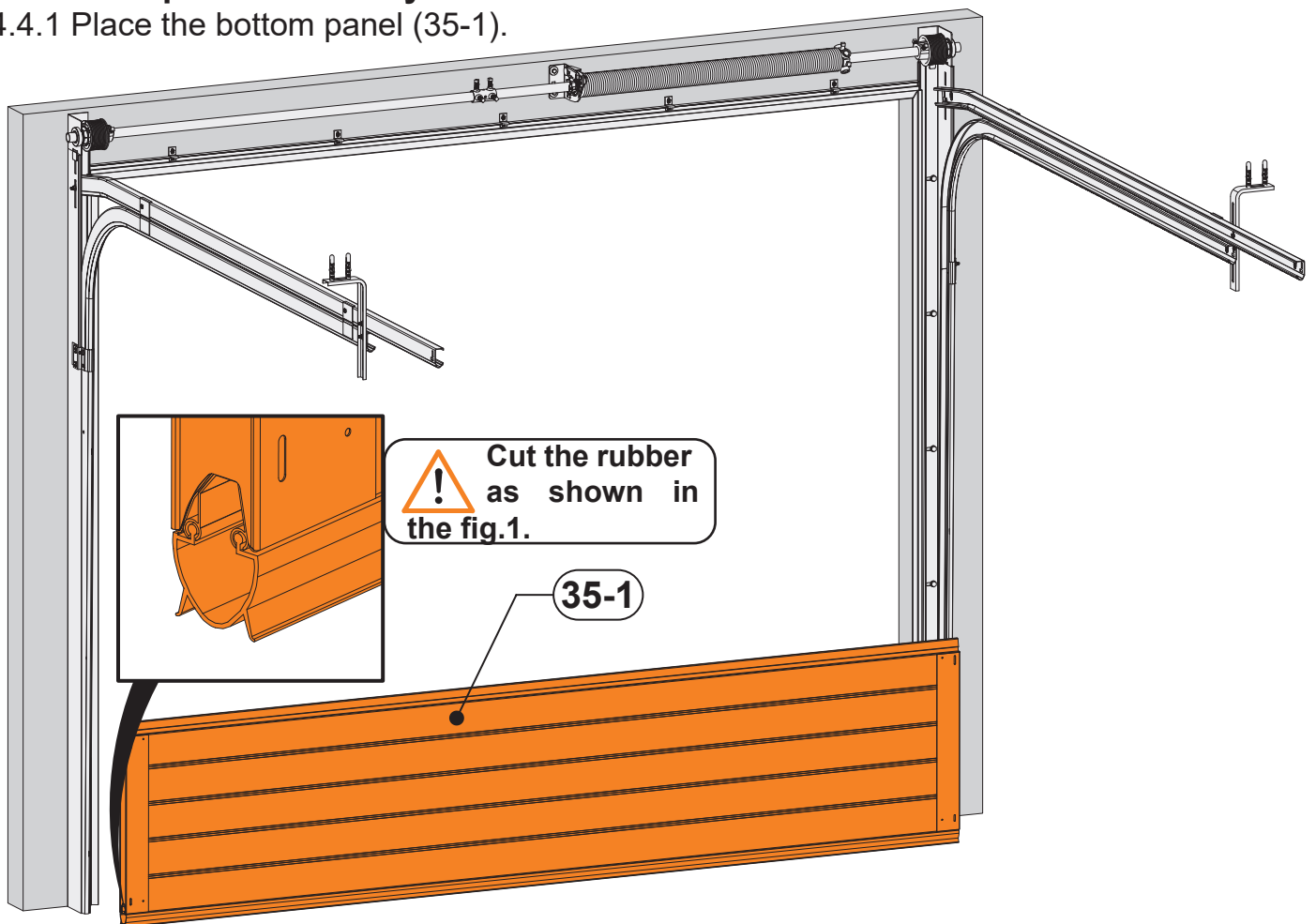

4.1.2 Assemble the left and right bottom brackets.

#### Left Bottom Bracket

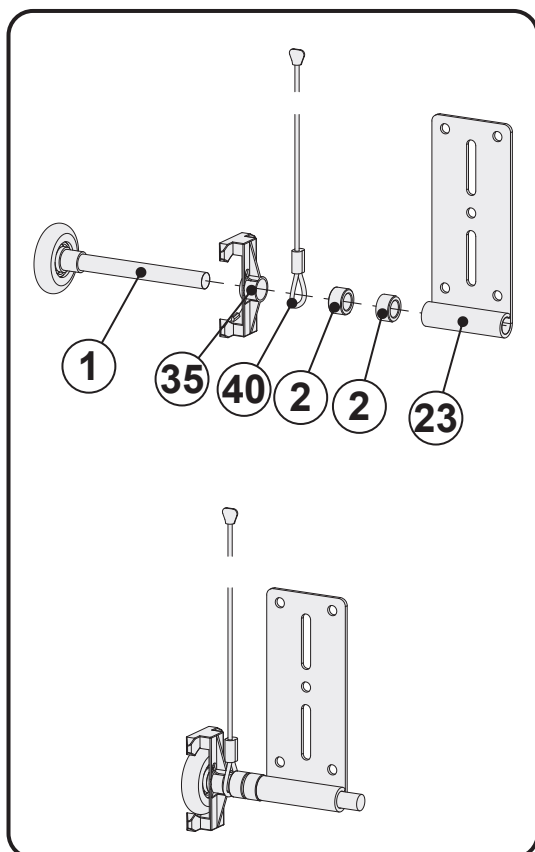

#### Right Bottom Bracket

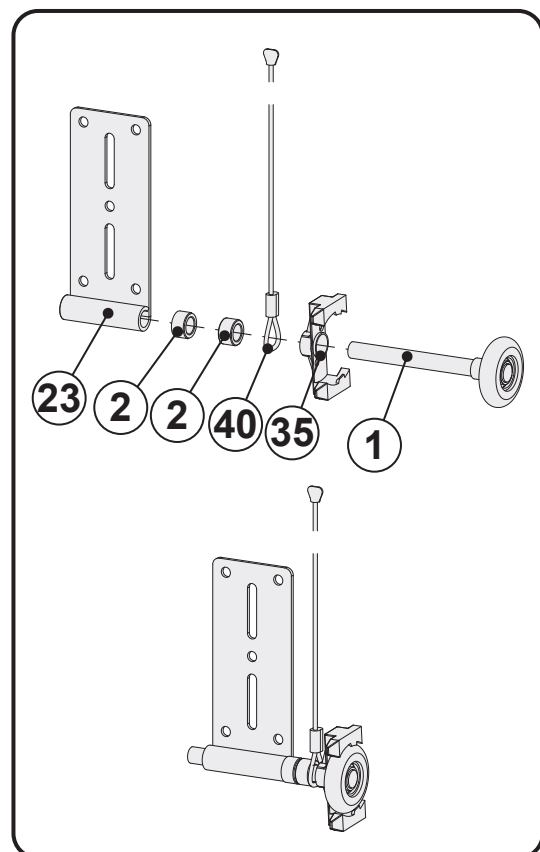

### 4.1.3 Place the left bottom bracket (23) in the track.

#### Tools

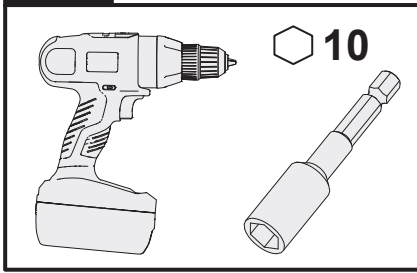

#### Parts

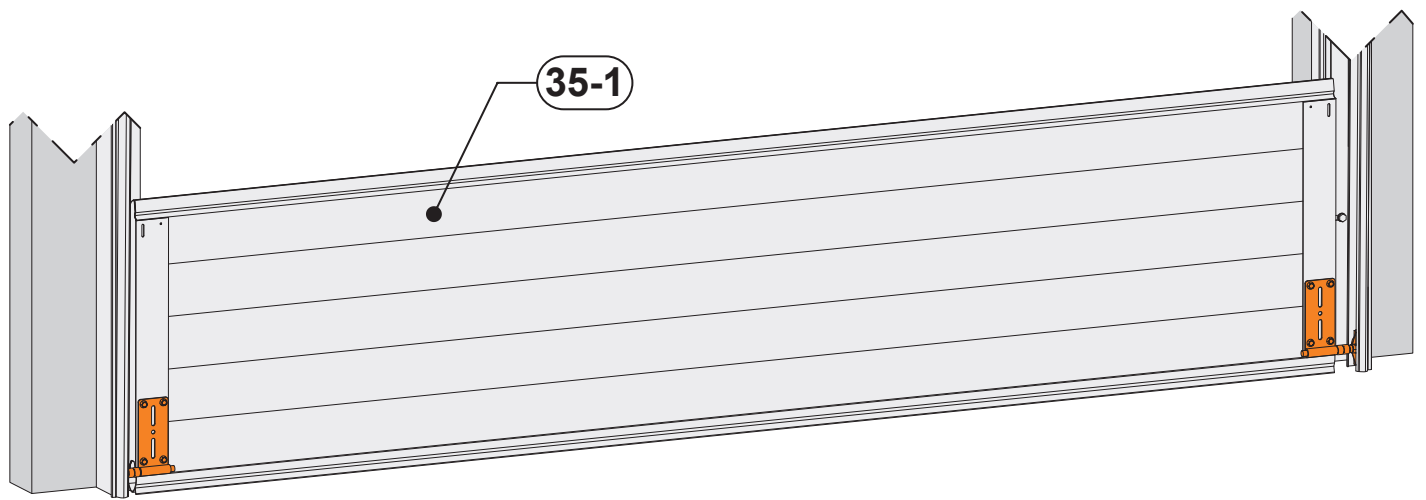
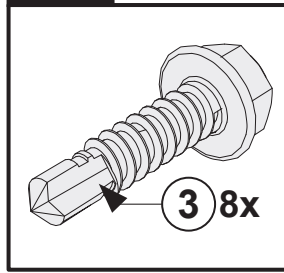

#### Step 1

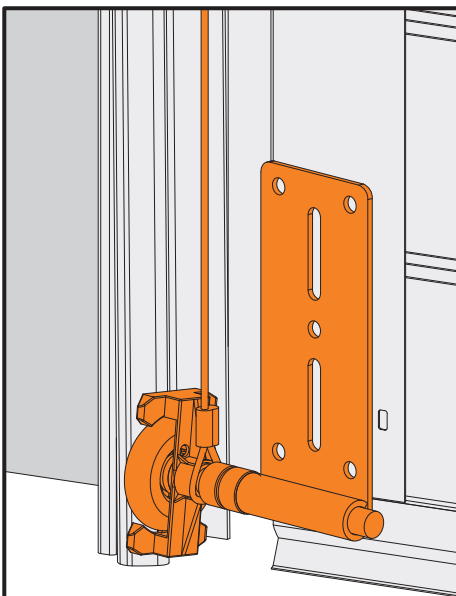

#### Step 2

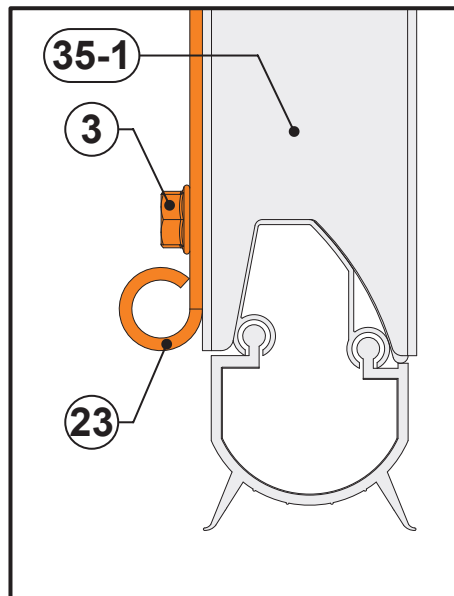

#### Step 3

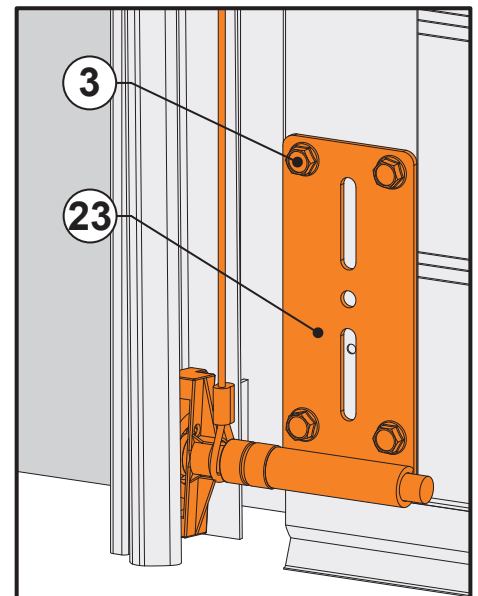

- 1 Insert the roller in the track.
- 2 The left bottom bracket support (23) should be aligned with the bottom of the panel.
- 3 Screw the left bottom bracket (23) into panel metal parts with bolts (3).

### 4.1.4 Repeat the step 4.1.3 for the right bottom bracket (23).

#### 4.1.5 Fixation of the left side hinges (33).

##### Parts

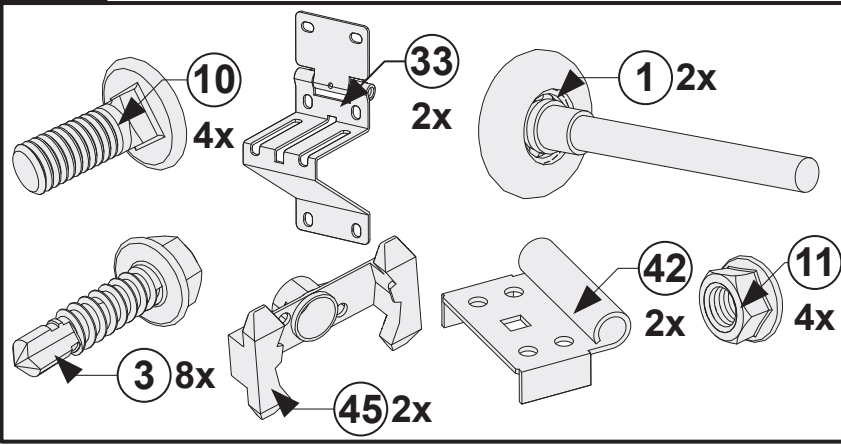

##### Tools

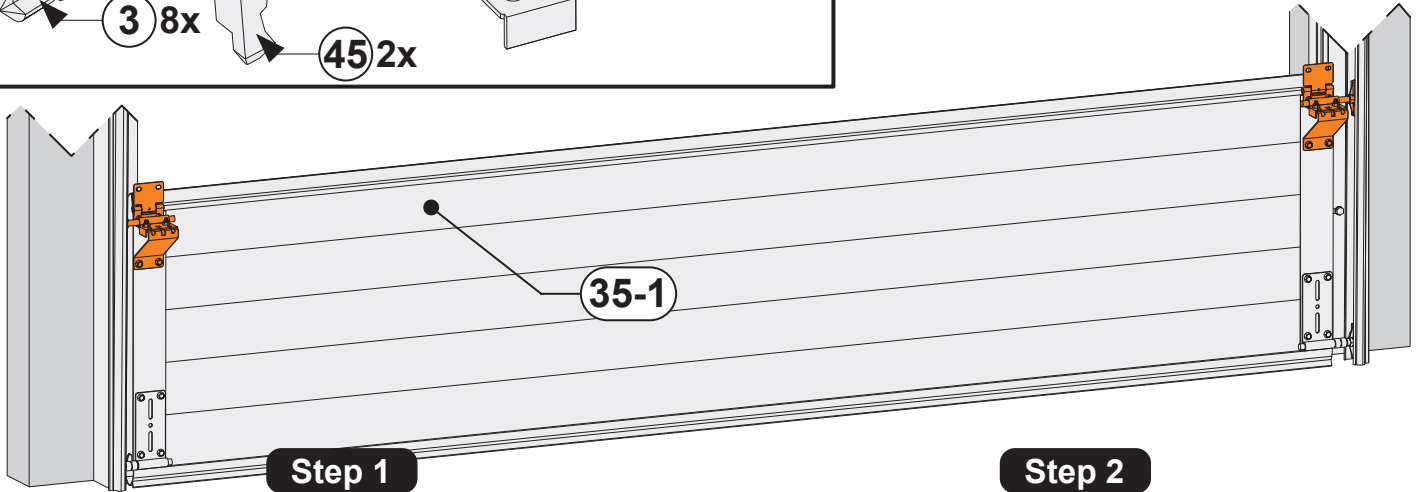
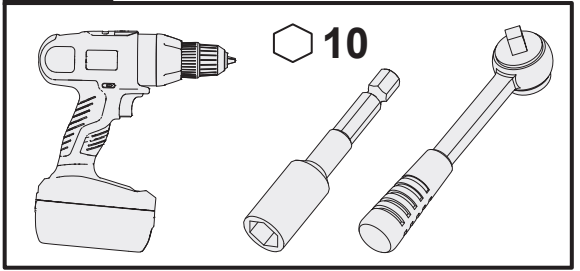

##### Step 1

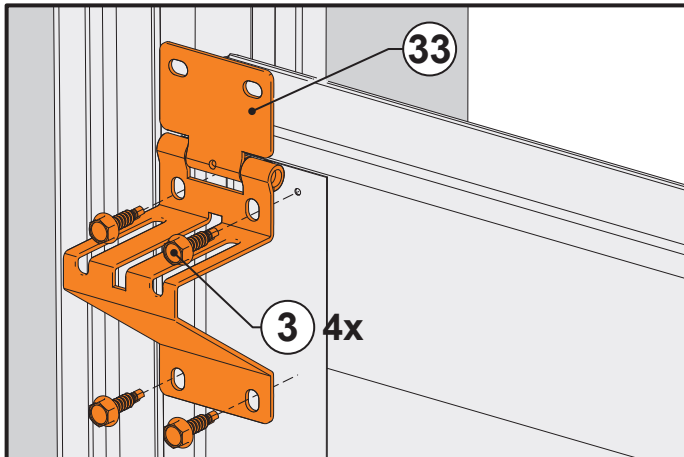

##### Step 2

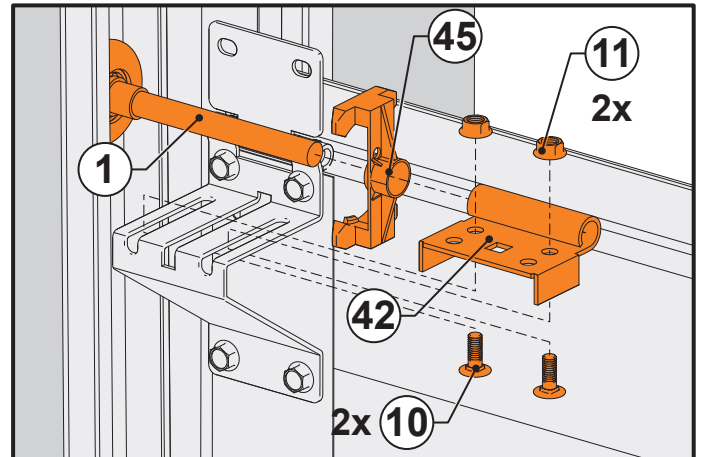

##### Step 3

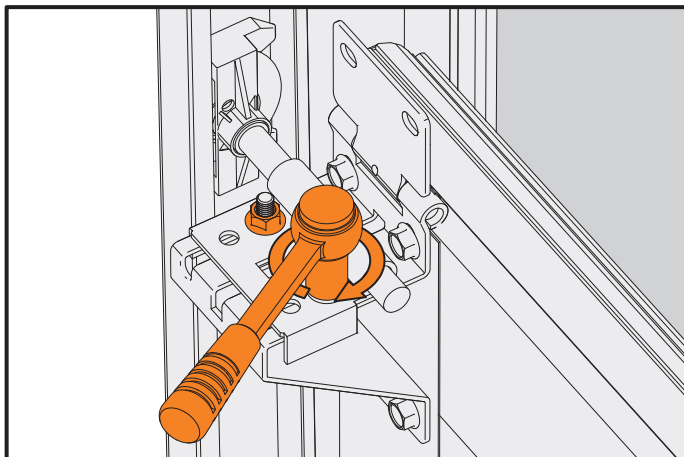

##### Step 4

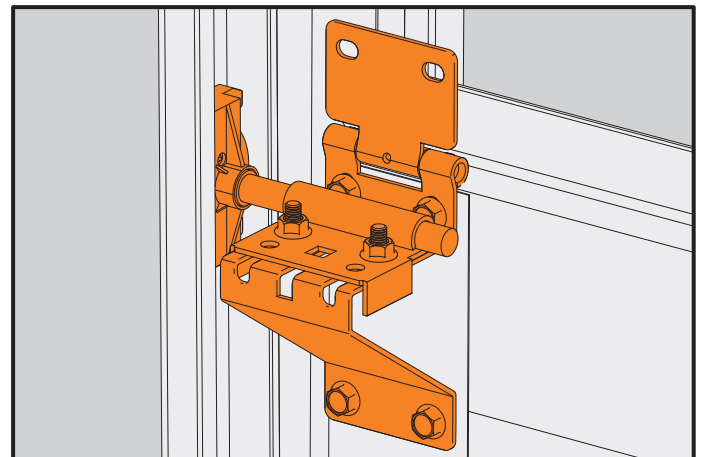

- 1 Screw the side hinge (33) in the top of the metal part of the panel with bolts (3).
- 2 Install the intermediate roller.
- 3 Insert the intermediate roller in the track and screw the roller support (42) in the side hinge using the bolts (10) and nuts (11).
- 4 The side hinge is placed.

4.1.6 Repeat the step 4.1.5 for the right side hinge (33).

## 4.2 Second panel assembly

4.2.1 Screw the upper part of the first three hinges (33) in the second panel (35-2), using the bolts (3).

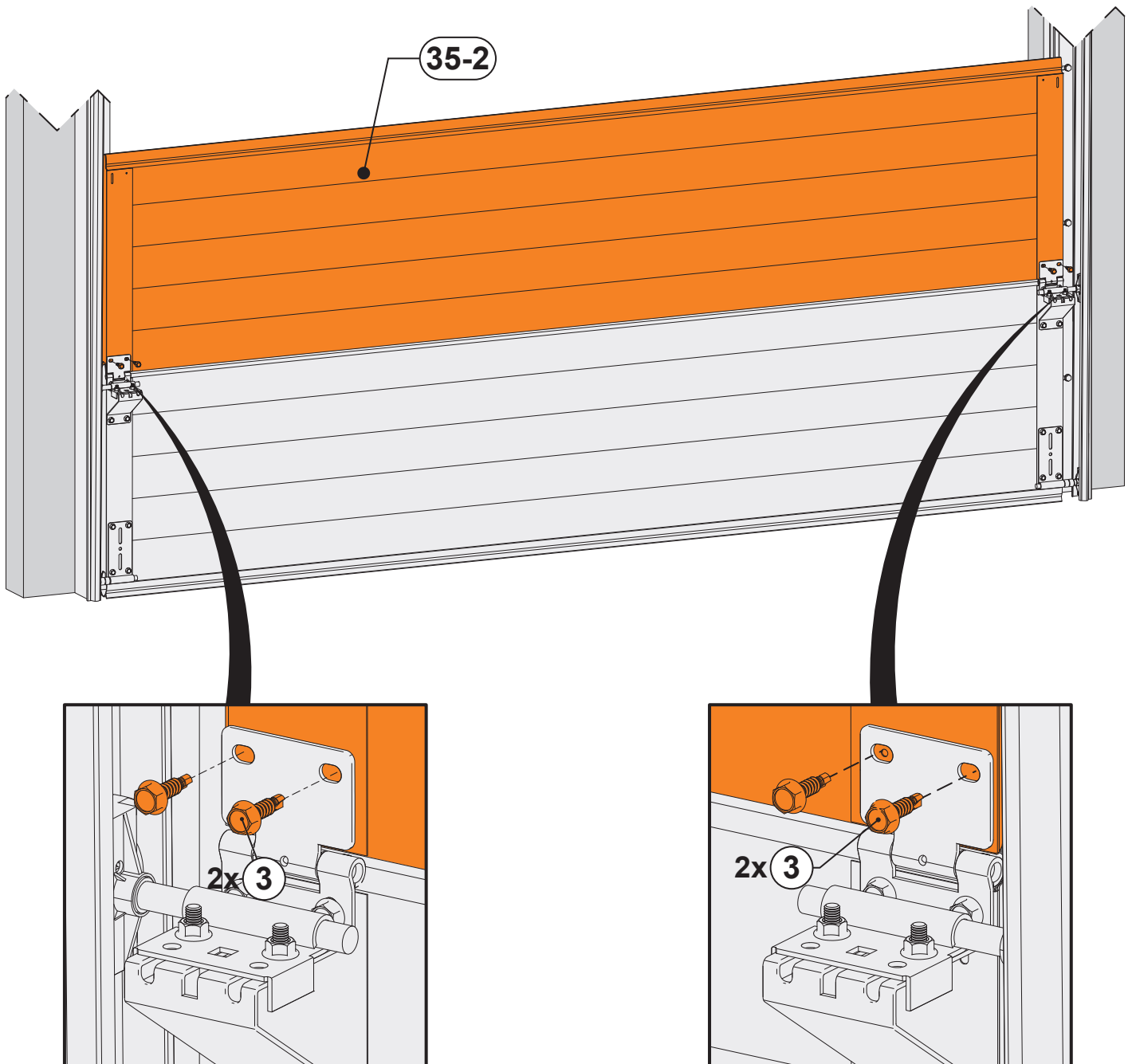
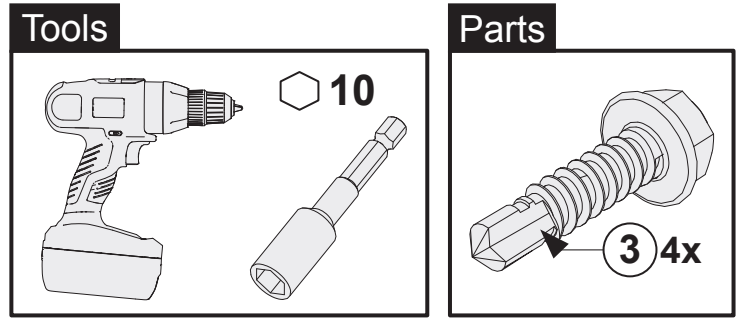

Repeat steps 4.1.5 and 4.1.6 on second panel

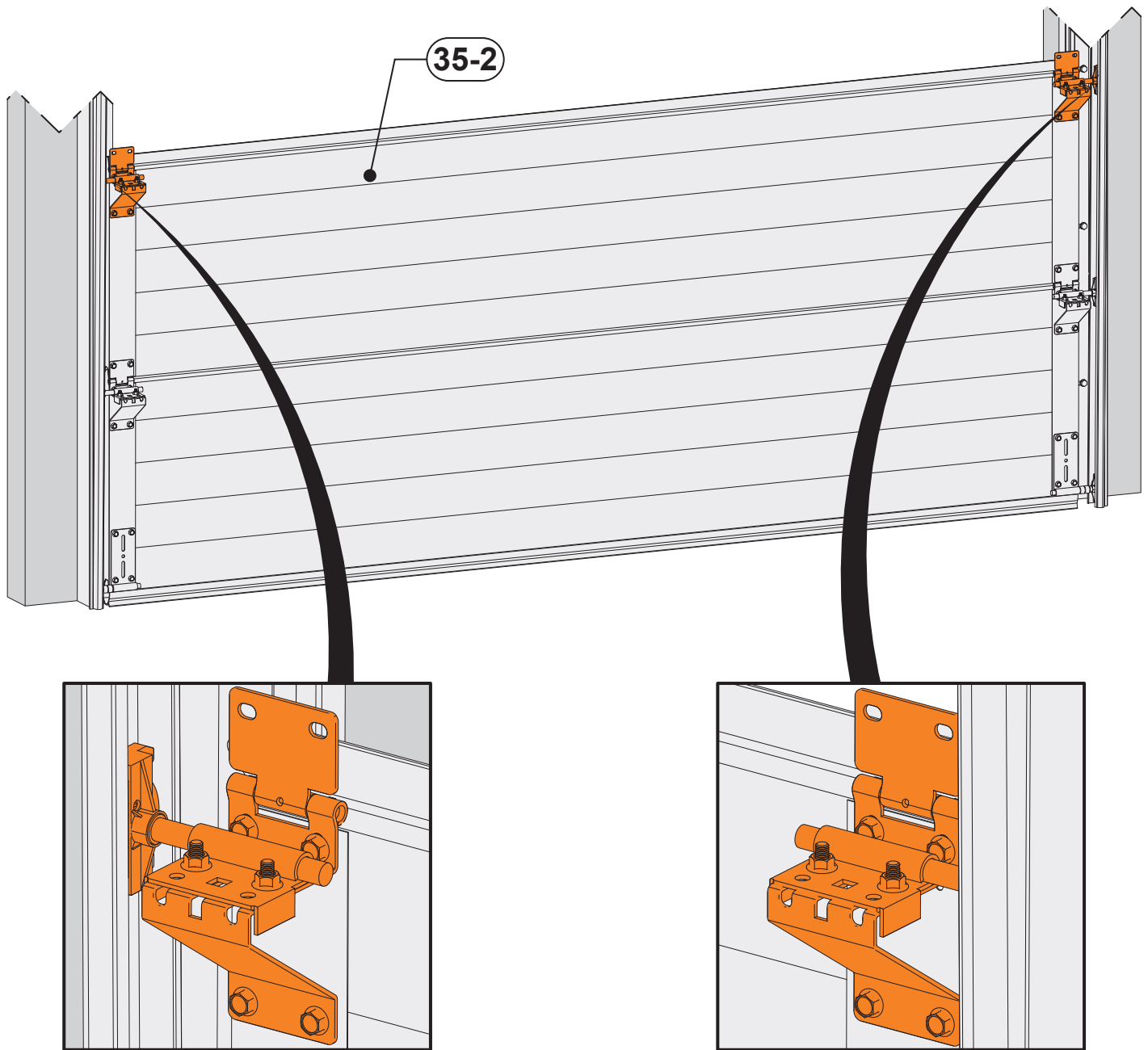

### 4.3 Third panel assembly

Repeat steps 4.2.1 and 4.2.2.

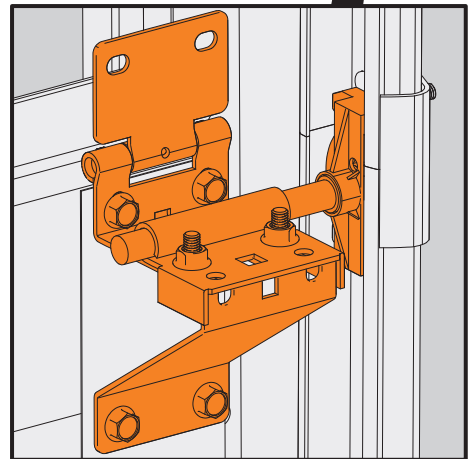
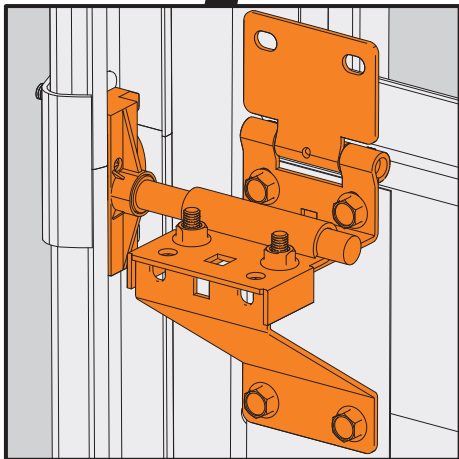
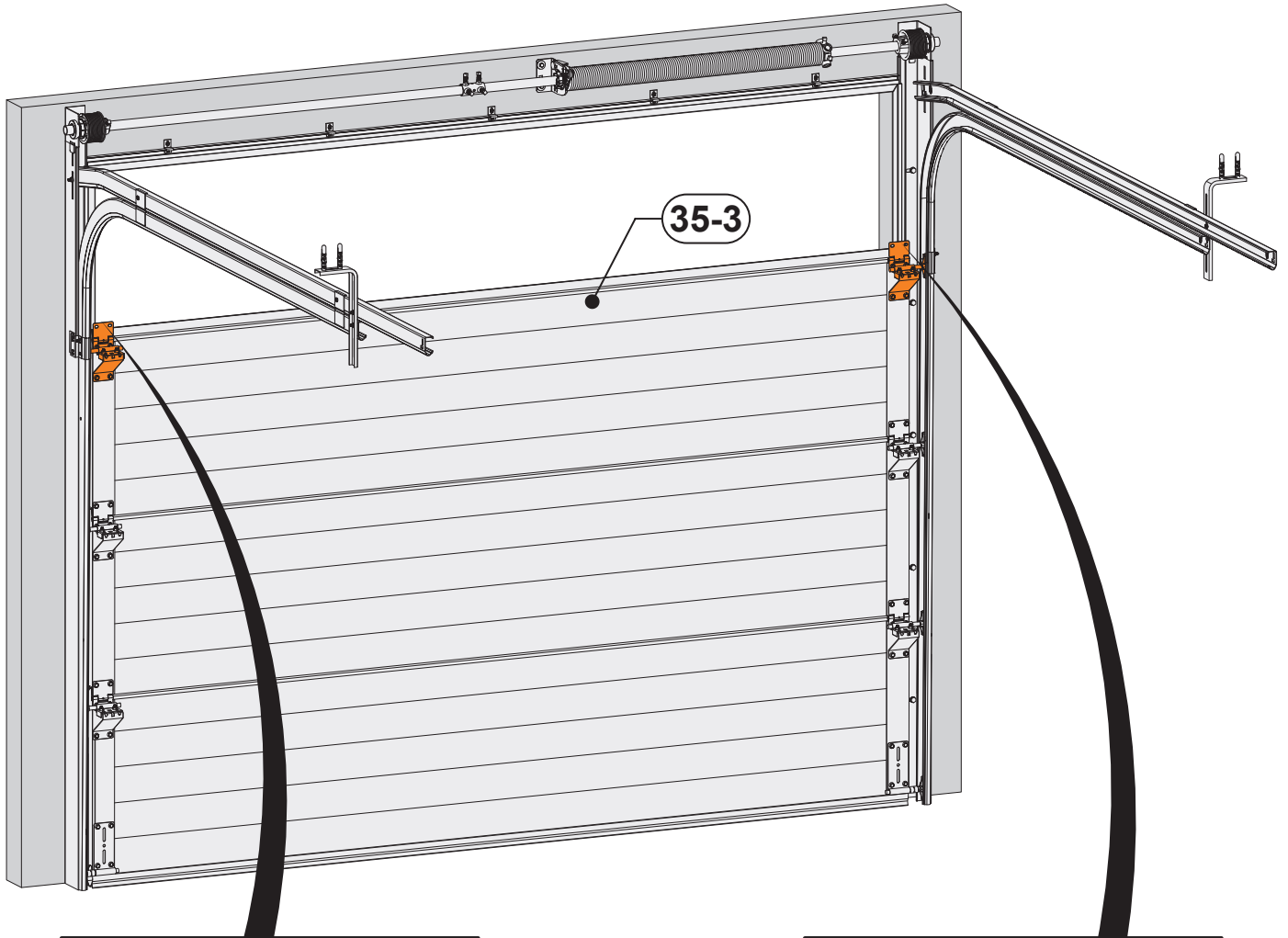

## 4.4 Top panel assembly

4.4.1 Install the upper rollers in the top roller bracket (23).

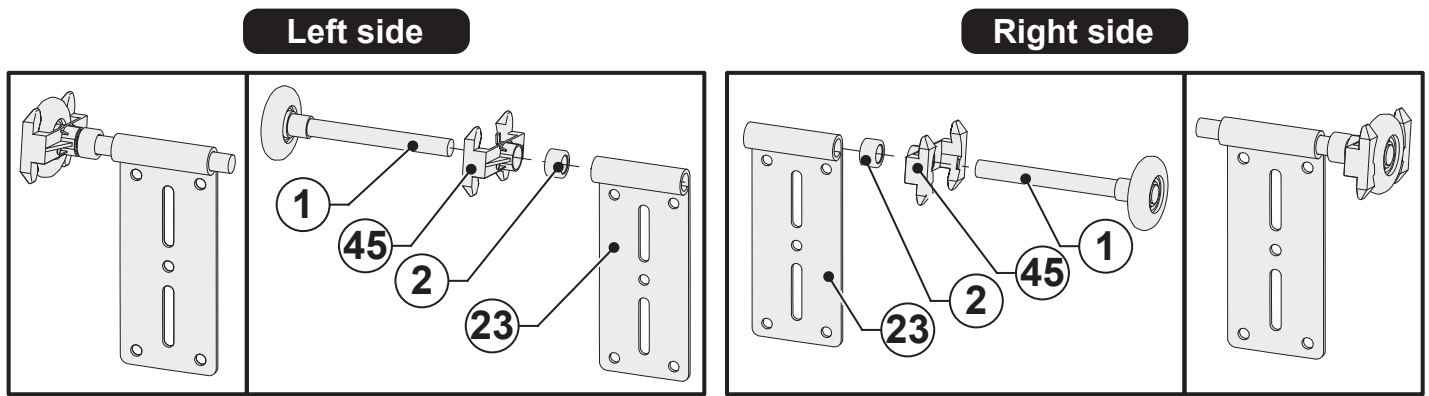

4.4.2 Screw the upper part of the first three hinges in the top panel with bolts (3) - Repeat step 4.2.1.

4.4.3 Insert the upper roller in the tracks (23) and screw the hinge in the panel using the bolts (3).

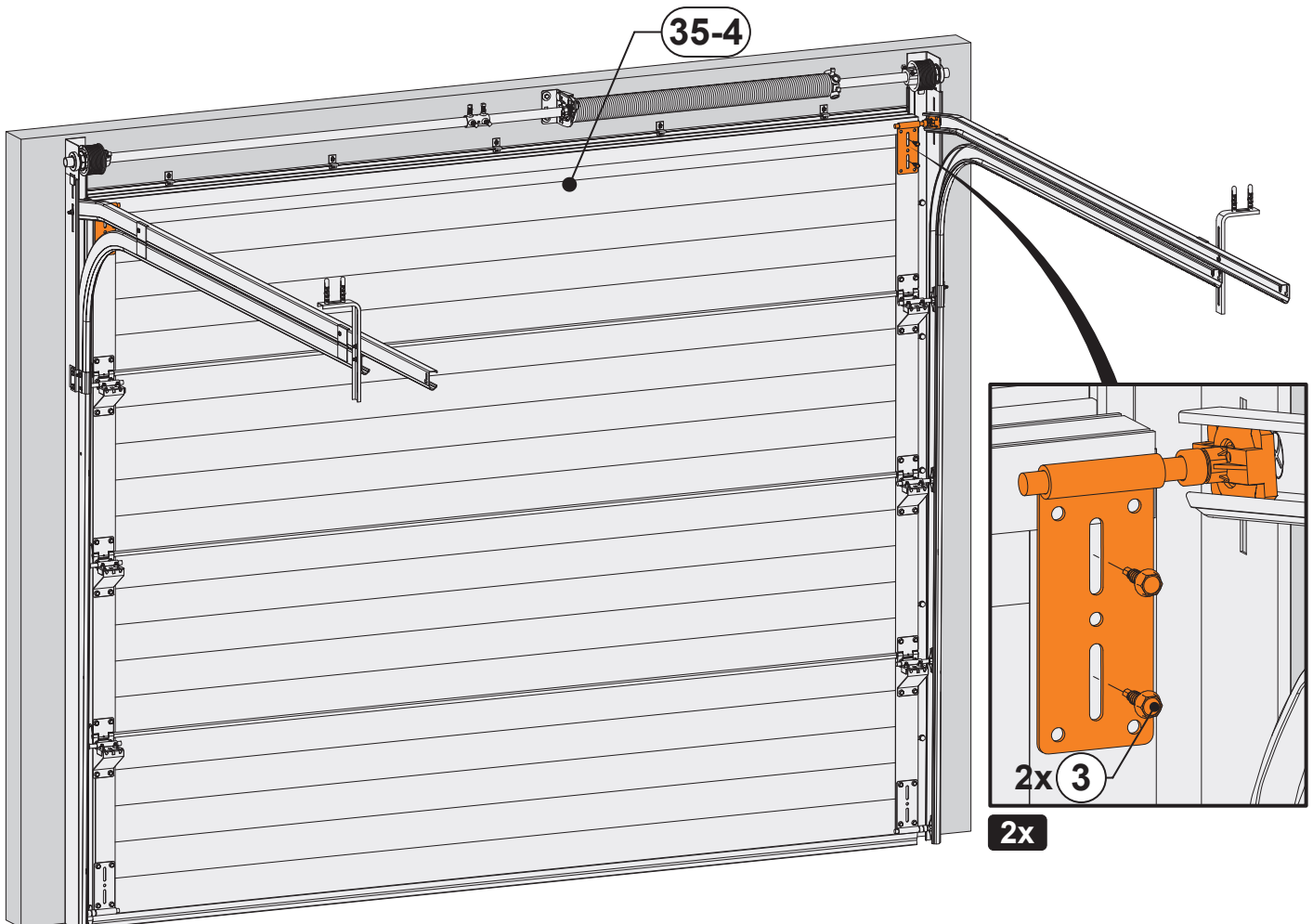
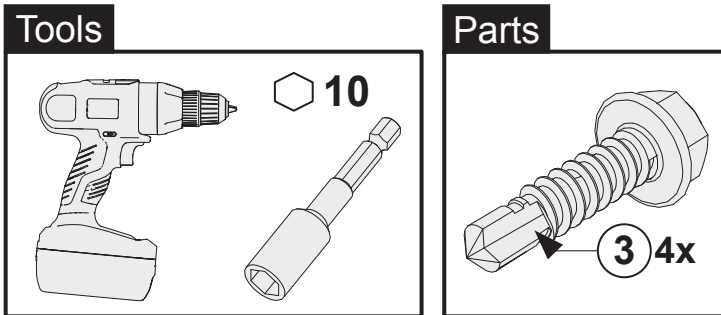

## 4.5 Installation of the handle

Screw the handle (37) in the panel using bolts (43).

### Tools

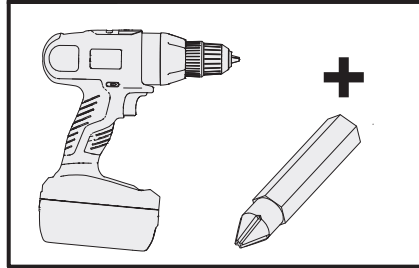

### Parts

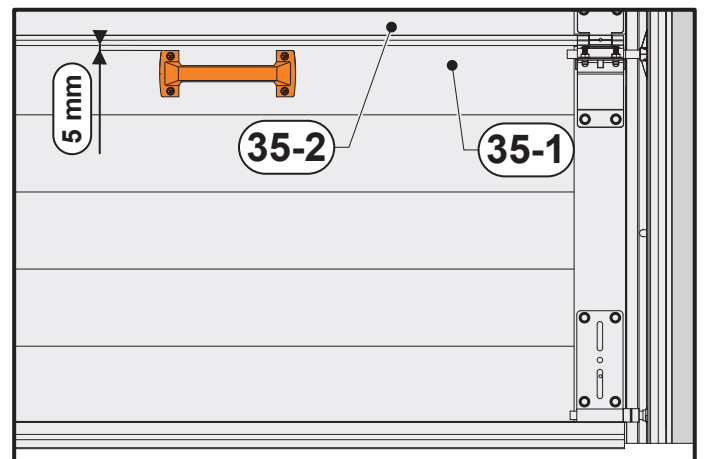
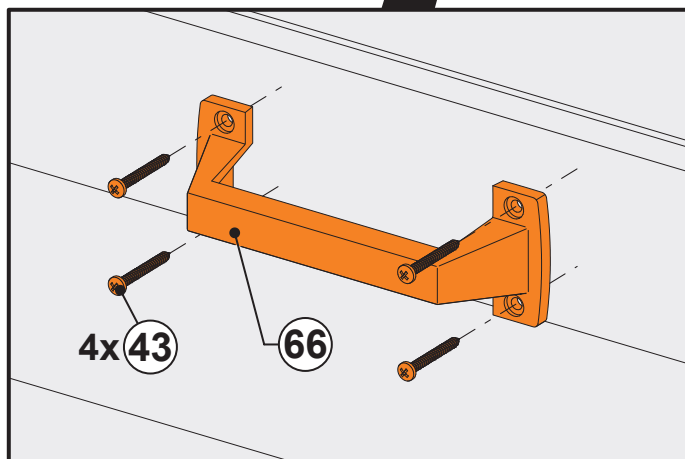
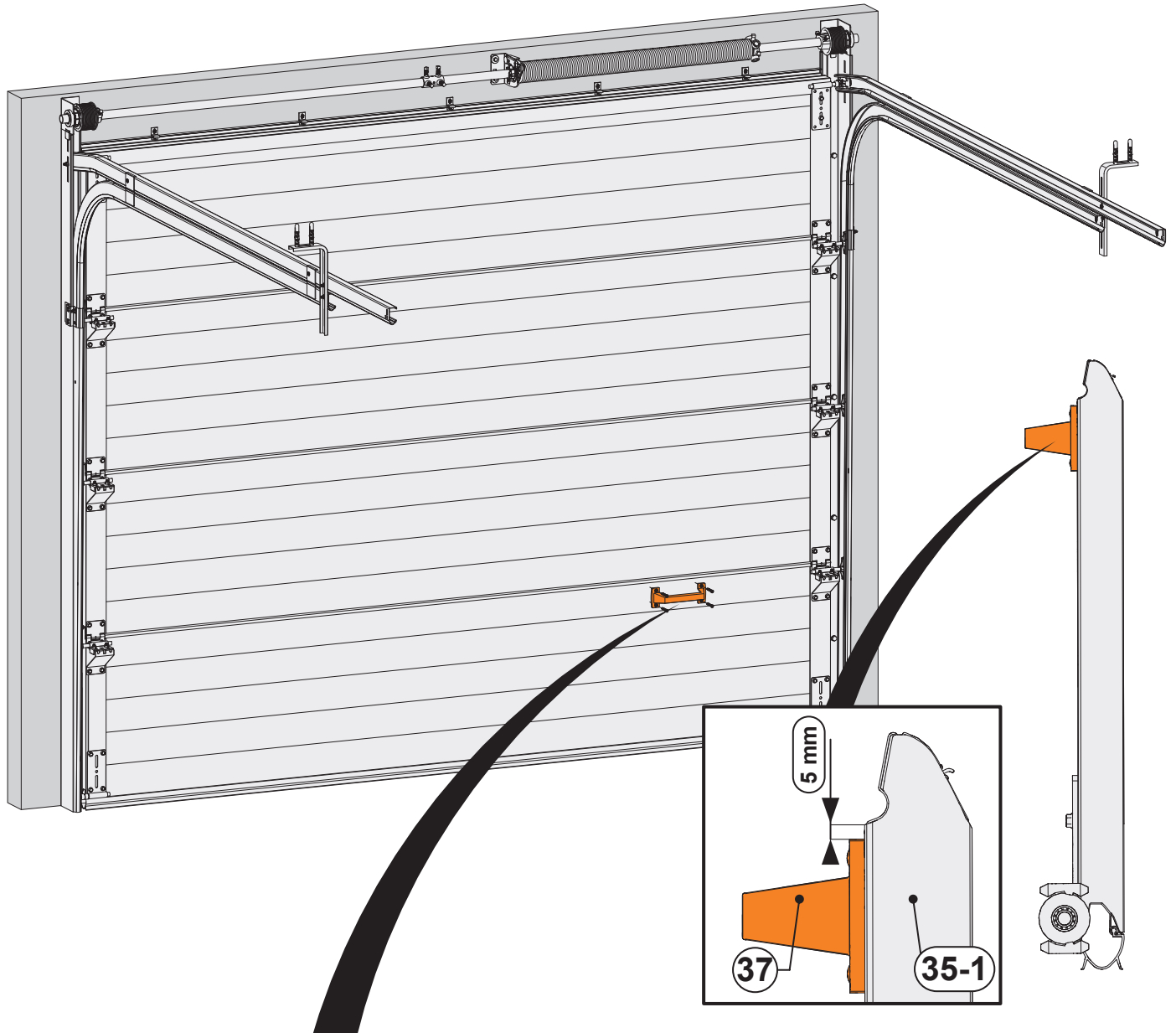
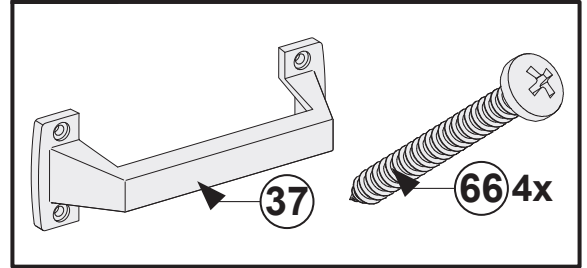



## 4.6 Fixation of the rubber stop on the horizontal tracks

Screw the rubber stop (63) on the horizontal tracks using bolts (10) and nuts (11).

### Tools

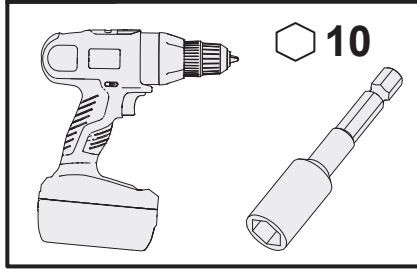

### Parts

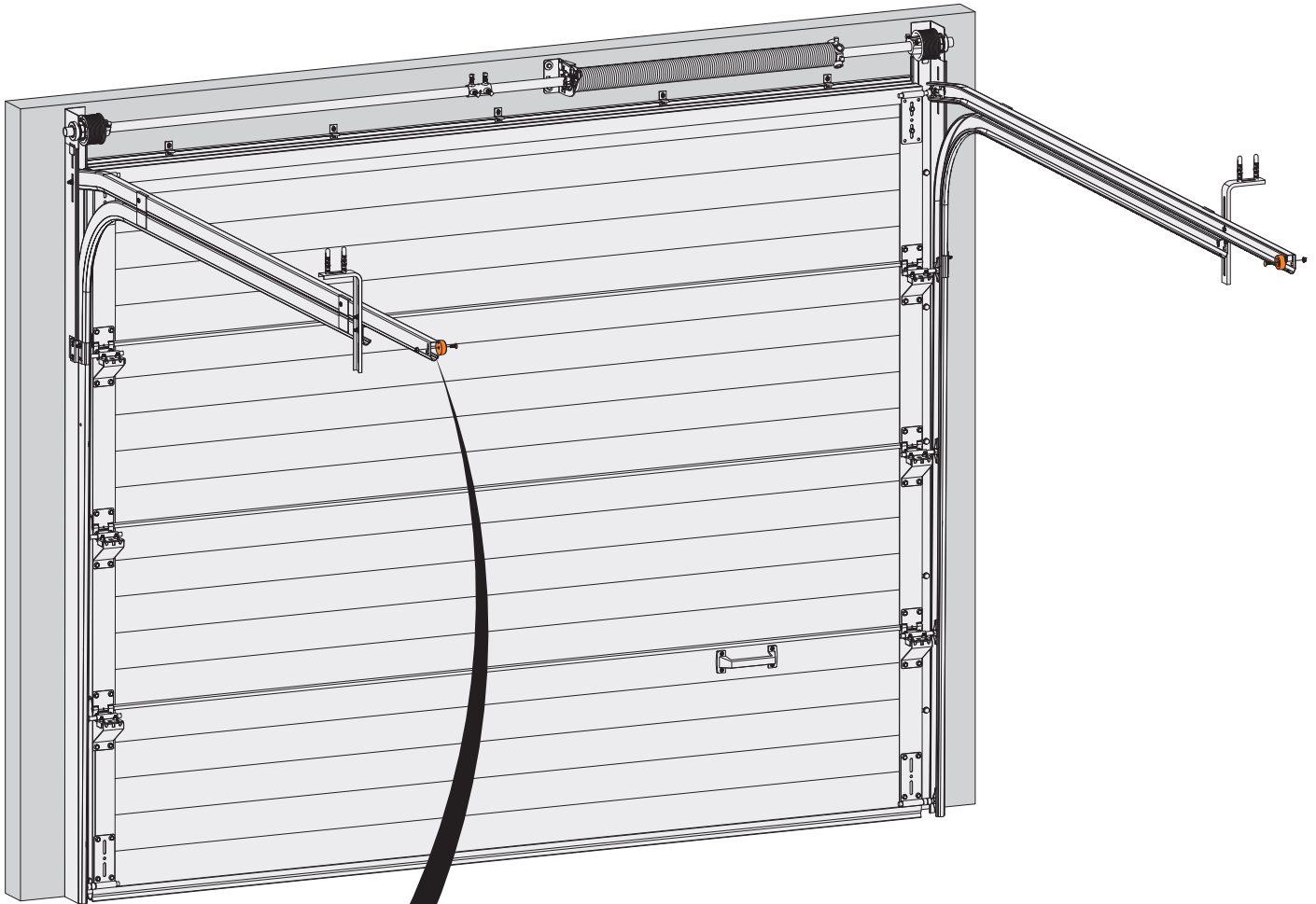
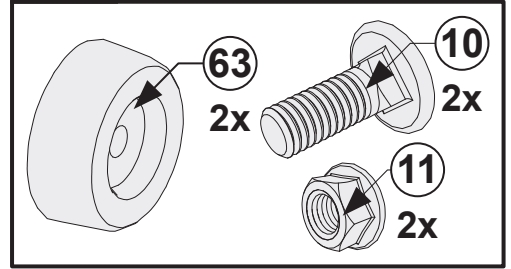

2x

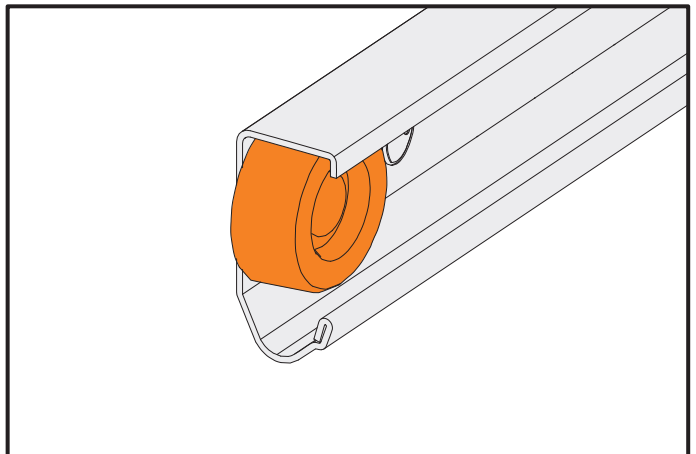
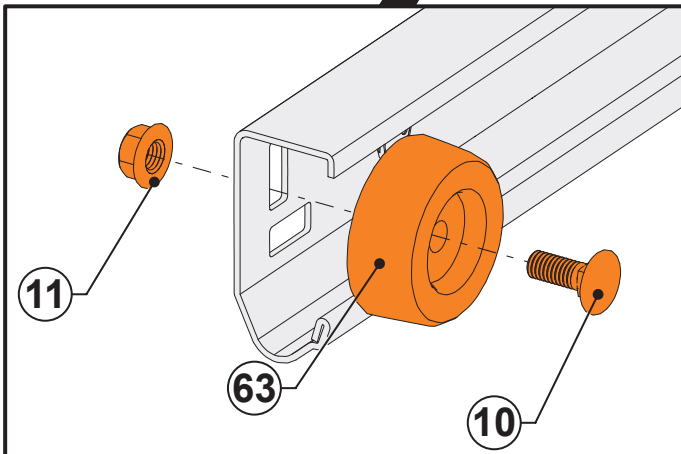

## 5. Installation of the cables

5.1 - Place the steel cable (40) mounted on the support (23) and place the near end (A) in the cable drum (16).

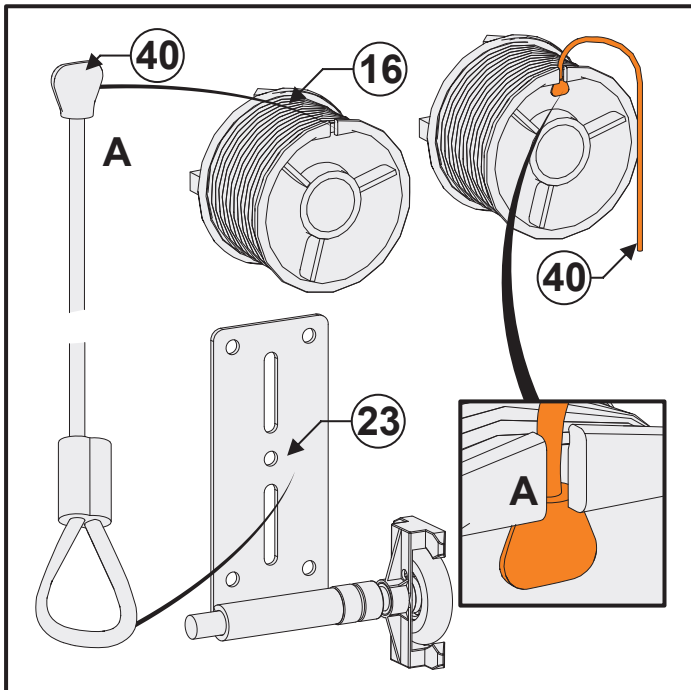

5.2 - Block the shaft with a locking pliers. Wrap the cable (40) around the cable drum (16) until it is tight.

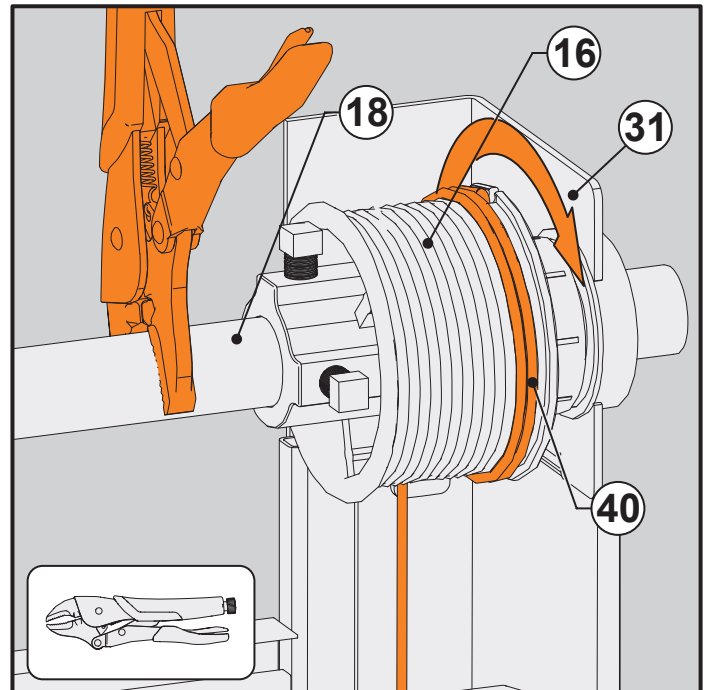

5.3 - Place the cable drums (16) against the bearings and screw the two bolts as shown in the figure.

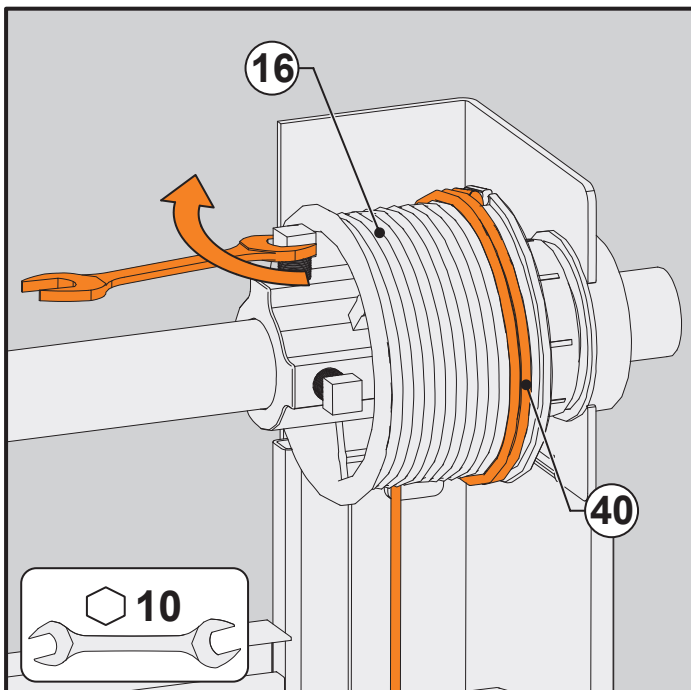

5.4 - Maintain the shaft with locking pliers so that the cable is tight.

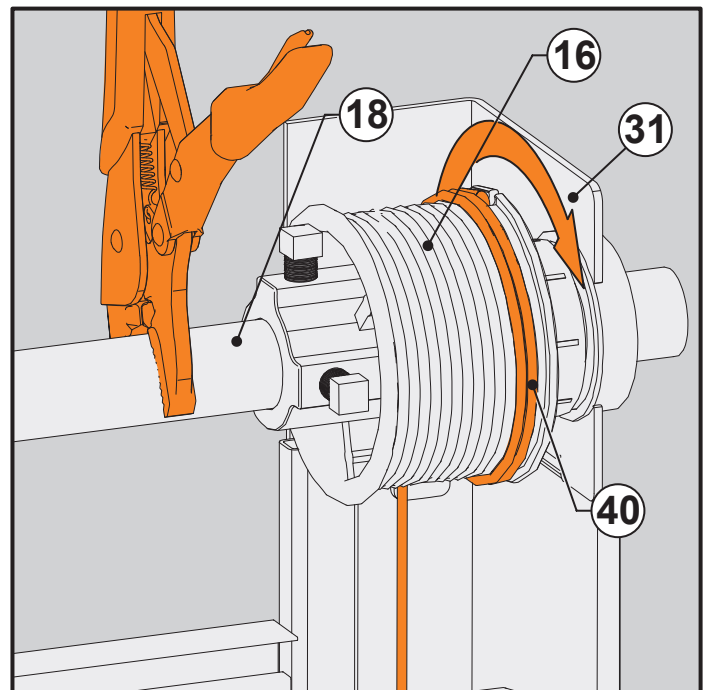

5.5 - Repeat with the second cable drum (19), making sure that both cables are fully inserted into the slot designed for this purpose.

 **Block the shaft with a locking pliers.**

## 6. Adjustments

### 6.1 Spring tension

#### ⚠ ATTENTION:

- The torsion turns on the springs is a very dangerous and delicate procedure, and must be performed by qualified personnel.
  - We advise the technicians to operate safely, paying close attention to the succession of maneuvers to be carried out using all the tools necessary to operate safely.
  - Perform this operation with the door closed, and put the clamp support to lock the lifting of the door.
  - The number of turns can be counted drawing a line in the spring, which helps to count the number of turns on the spring with the diagonal lines on the springs, as shown in figure 6a and 6b.
  - With the help of two tension sets or bars (A) proceed according to figure 6a, placing them in appropriate slots of the spring fitting (B). (Detail A).
  - Never release the two bars to prevent accidents caused by the spring force.
- Perform the number of turns required, as described in the CE marking label (3rd panel) (see number of spring turns)**

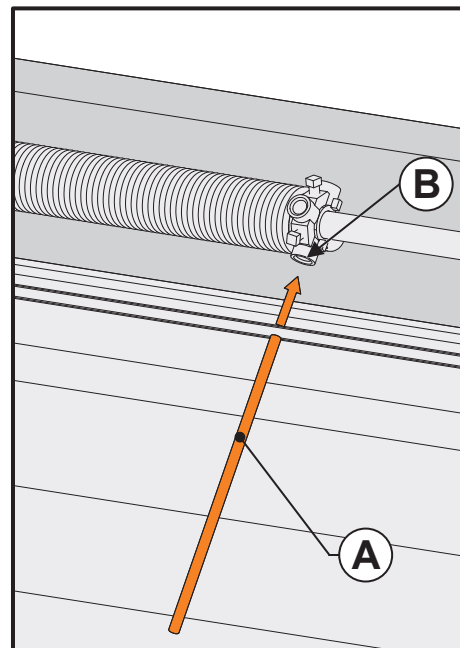

Figure 6a

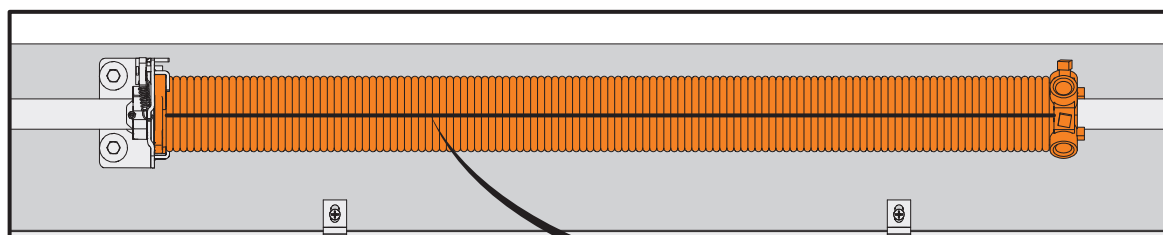

Figure 6b

Spring without tours

Line to count the number of turns

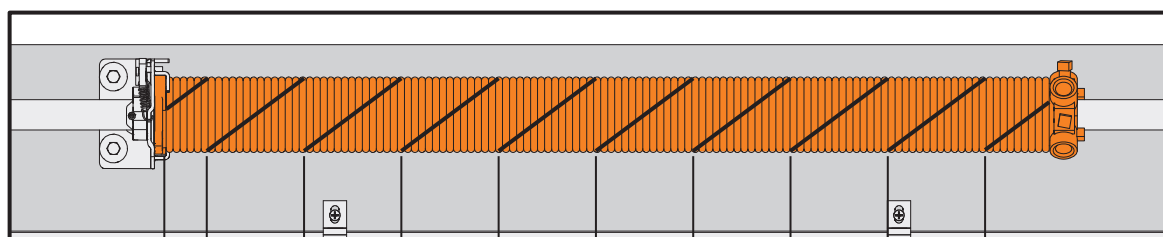

Figure 6c

Spring with the required number of turns

N.º of turns

Flexidoor	
<small>Flexidoor - Portões Seccionados e Automáticos, S.A.                      Rua da Majeira nº400, Ponte de Pedra                      2415-184 Requena de Portos - Portugal</small>	
<b>Standard EN 13241-1:2003+A1:2011</b> 009/CPR/19-09-2013	
<b>Door type</b> Sectional door with frame panel Z2	
<b>Model</b>	<b>Type of Use</b>
PRIM/CK/SBL	Garage / Industrial
<b>Production Date</b>	<b>Serial Nº / O.F.</b>
20.11.2013	0810/11/13
<b>Width</b>	<b>Height</b>
2400	2000
<b>Lintel</b>	
	180
<b>Nº Turns of Spring: N</b>	
<b>Cable Drum - Nº of Free Conical Turns: 3</b>	
<b>Resistance to Wind Load</b>	<b>Water Tightness</b>
Class 2	NPD
<b>Sound Insulation (dB)</b>	<b>Thermal Resistance</b>
Z2	NPD
<b>Air Permeability</b>	<b>Mechanical Durability</b>
NPD	15000 cycles
<b>Other characteristics declared:</b> -Operating Forces*: Pass -Release of dangerous substances: NPD -Definition of geometry of glass components: NPD -Force for Manual Operation -Safe opening -Mechanical Resistance -Protection against Cutting and Tripping -Protection against crushing, shearing and drawing-in -Electrical Safety -Electromagnetic Compatibility *Evaluation of conformity based on initial type testing	
<small>Mod.041-02                      Made in Portugal</small>	
<b>Directives:</b> Reg. nº 305, 2004/108/CE 2006/42/CE, 2011/65/EU RoHS 1999/5/EC RTTE, 2006/95/CE LVD	

Figure 6d

## Setting the torsion turns on the spring



Never release the two bars to prevent accidents caused by the spring force.

**6.1.1** Insert the 1st tension lever (A) completely into the slot of the spring fitting (B).

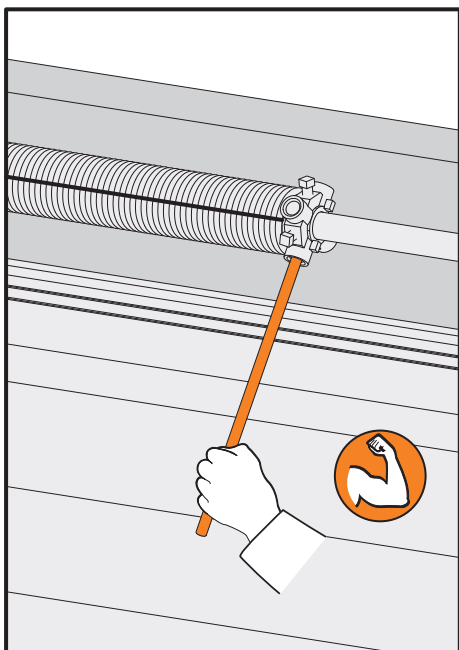

**6.1.2.** Turn the 1st tension lever a quarter turn such that the spring is tensioned.

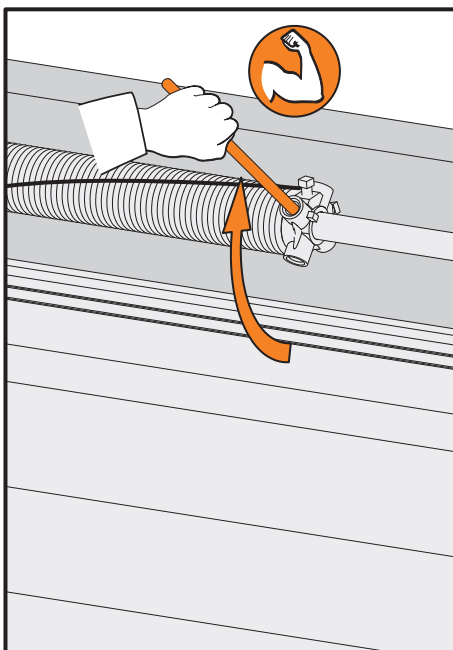

**6.1.3.** Insert the 2nd lever completely into the next slot of the spring fitting.

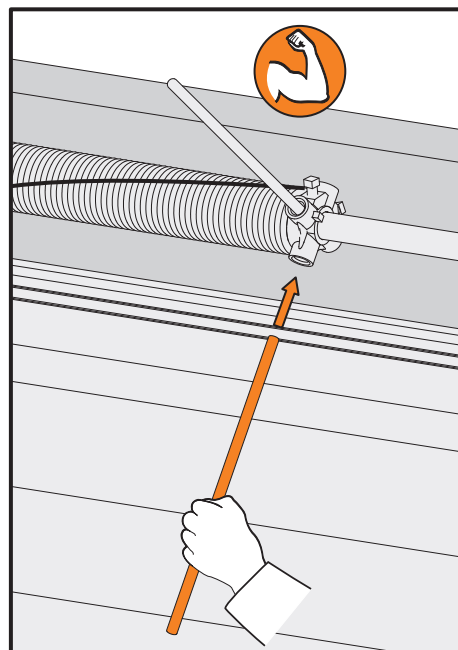

**6.1.4.** Hold the spring tension of the 1st tension bar with the 2nd bar.

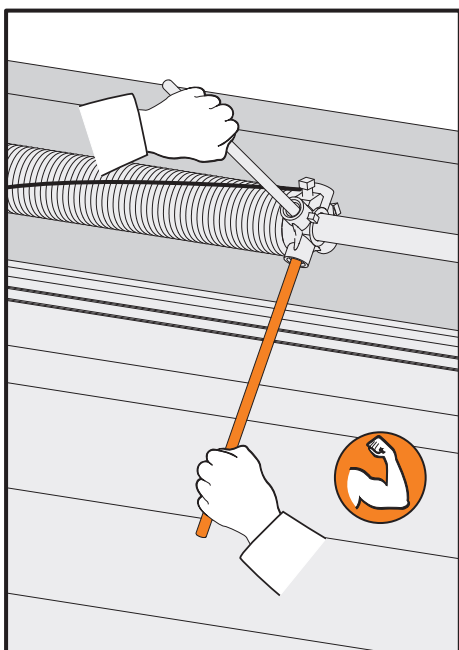

**6.1.5.** Remove the 1st tension lever from the slot.

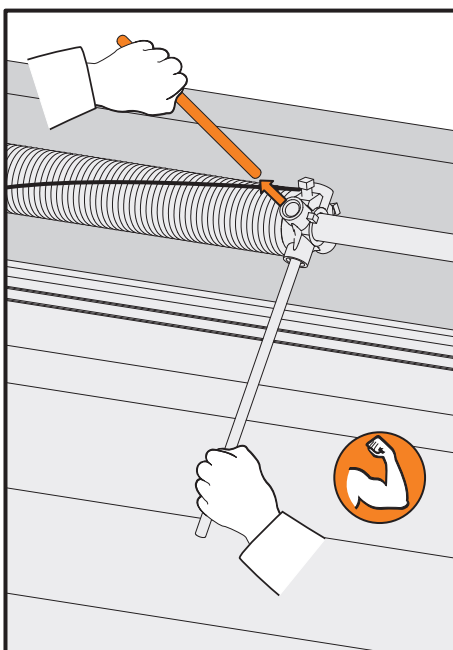

**6.1.6.** Turn the 2nd tension lever a quarter turn such that the spring tension increase.

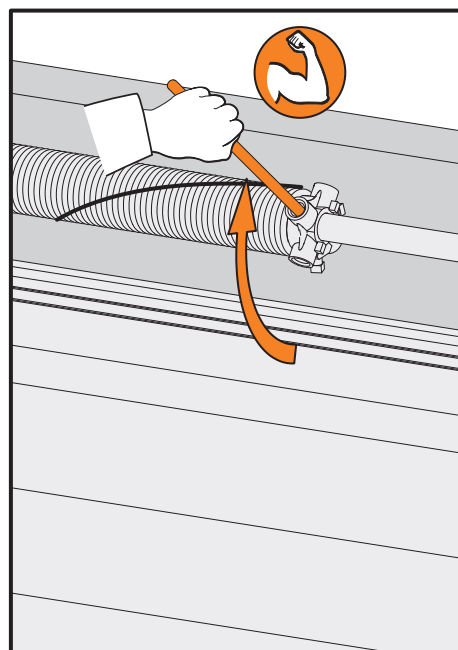

**6.1.7.** Powtórz kroki od 1 do 6 do osiągnięcia odpowiedniej ilości obrotów sprężyny (opis na naklejce CE (panel nr 3), zobacz ilość obrotów sprężyny).

6.1.8. Fix the spring plug to the shaft tube (17Nm). If it is shaft tube with key, put one of the screws in the key of the shaft.

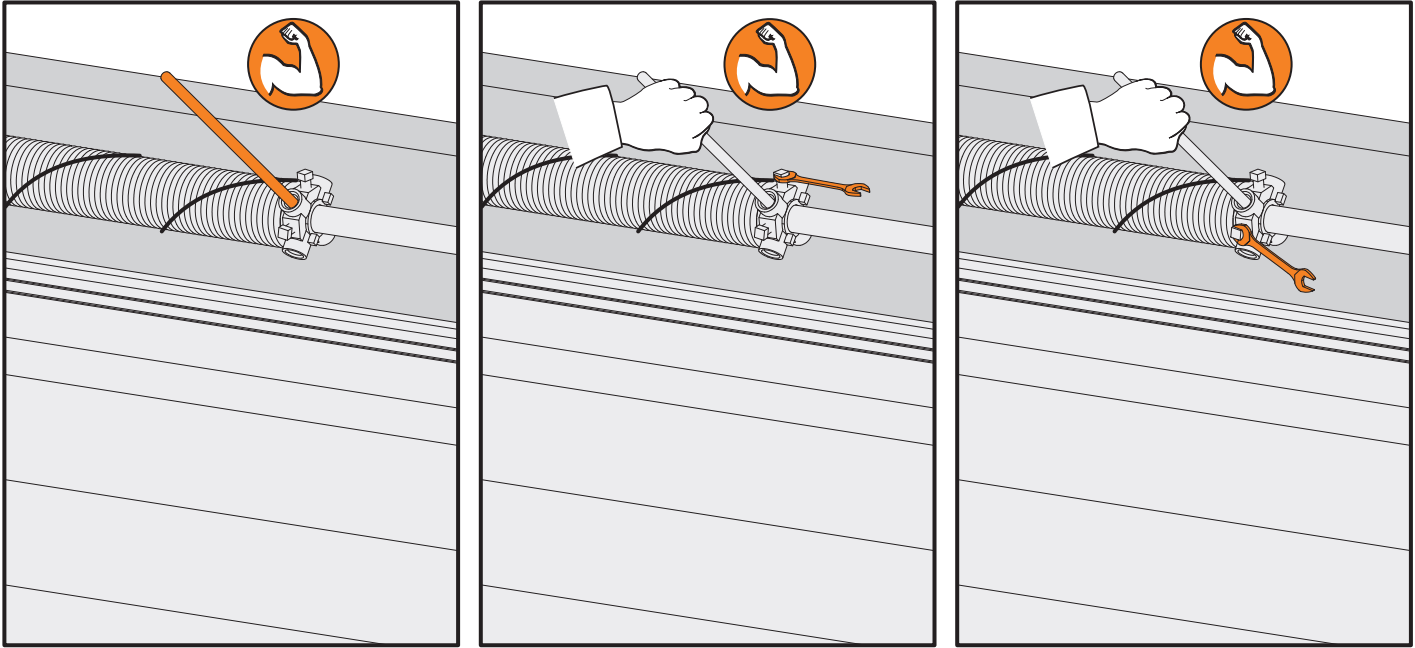

6.1.9. Remove the tension lever from the slot.

**!** If the sectional door not rise, **remove the spring break device pin (14) (figures 6f and 6g).**  
 Next remove the two clamps the shaft and release the door.

**!** Remove this pin from the spring break device.

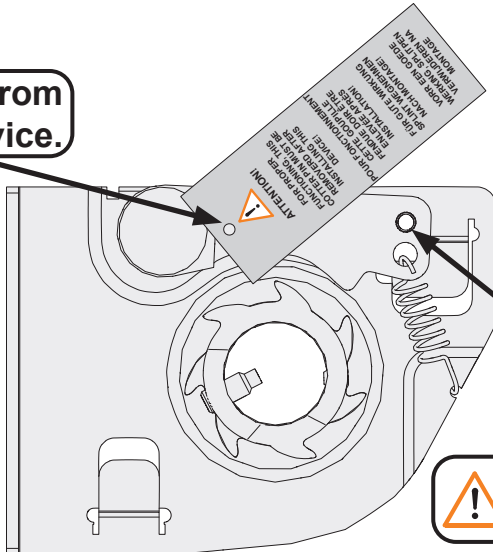

**!** Don't remove this pin from the spring break device.

Figure 6d

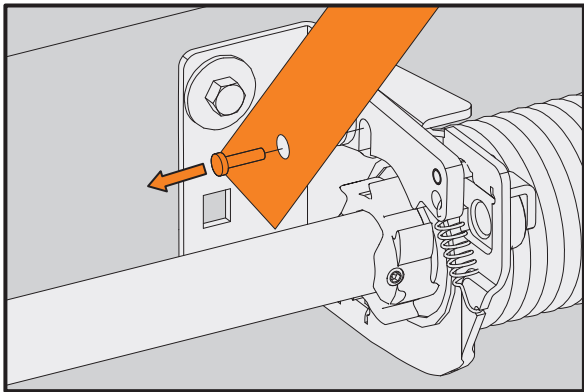

Figure 6e

### **Final step of the spring**

Test the door manually (figures 6f and 6g) to see if it is properly equilibrated, lifting/lowering the door without too much force, otherwise, proceed in the same way (chapter 6.1) and add or remove a little more force to the spring, depending on your needs.



**ATTENTION:** Check for the correct number of spring turns when the door is well balanced: the number of turns shown is merely an indication, there can be small variations.

If the sectional door rises rapidly and hardly descends or door is hard to rise and descends, should consult chapter 9. Troubleshooting to correct the installation.

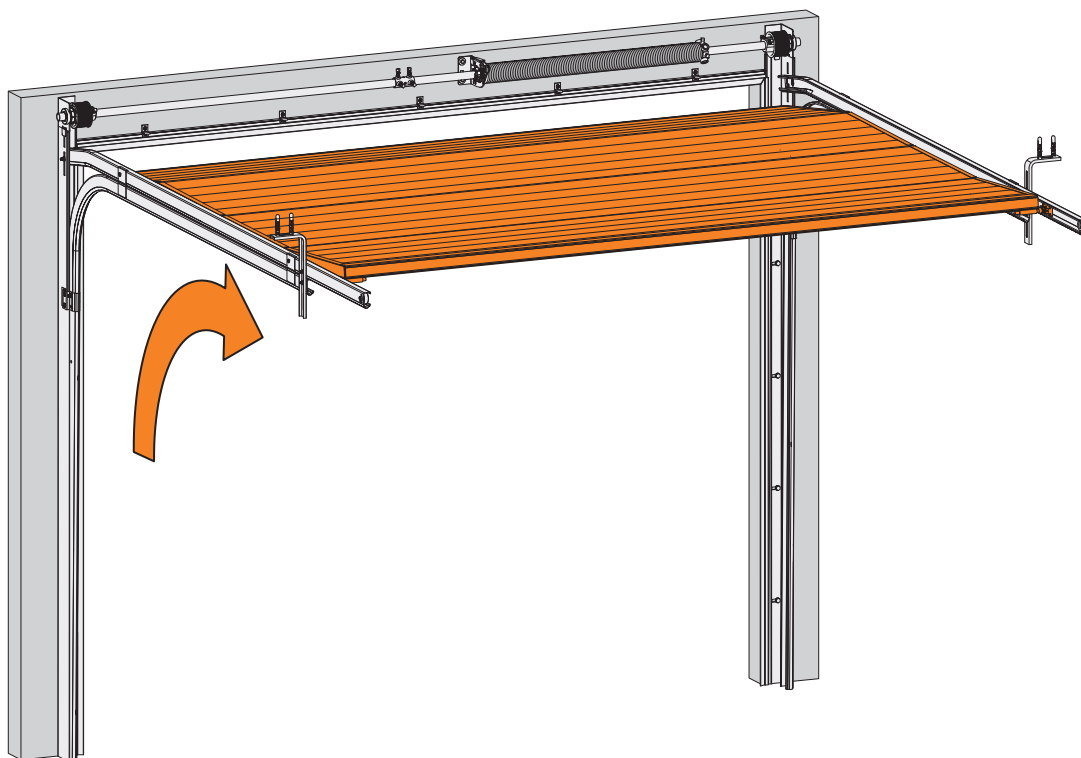

**Figure 6f**

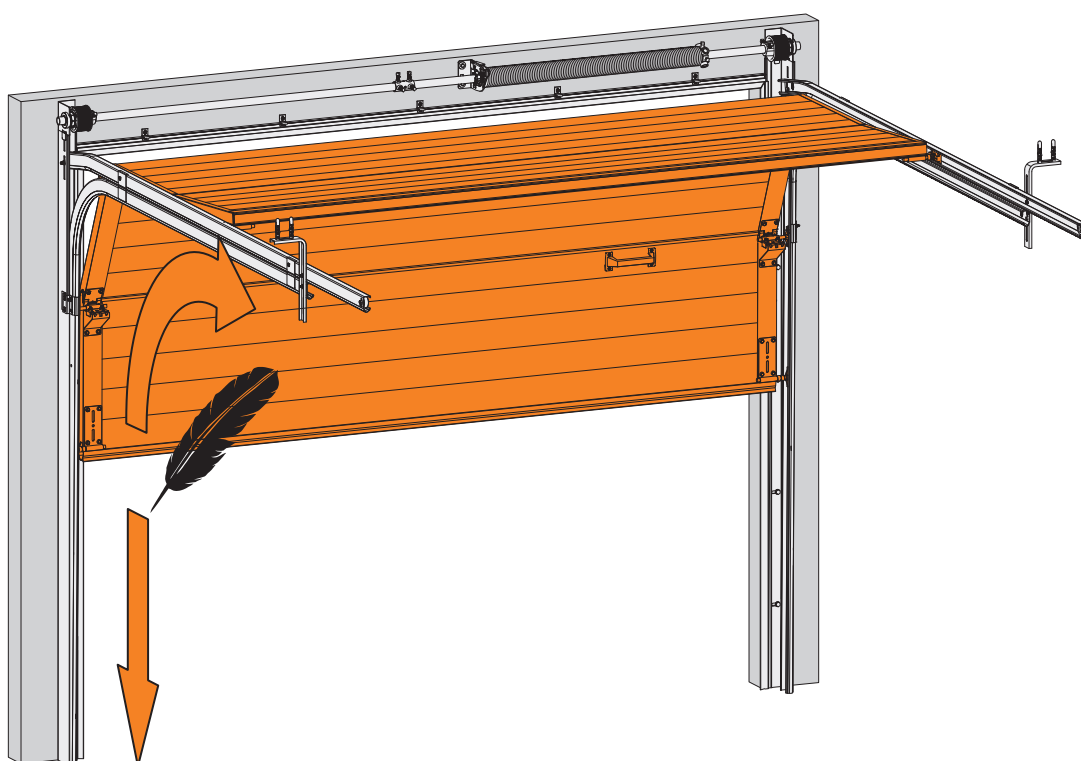

**Figure 6g**

## 6.2 Top roller bracket adjustment

### Tools

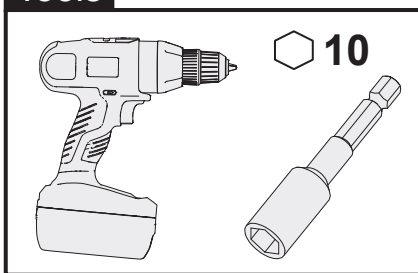

### Parts

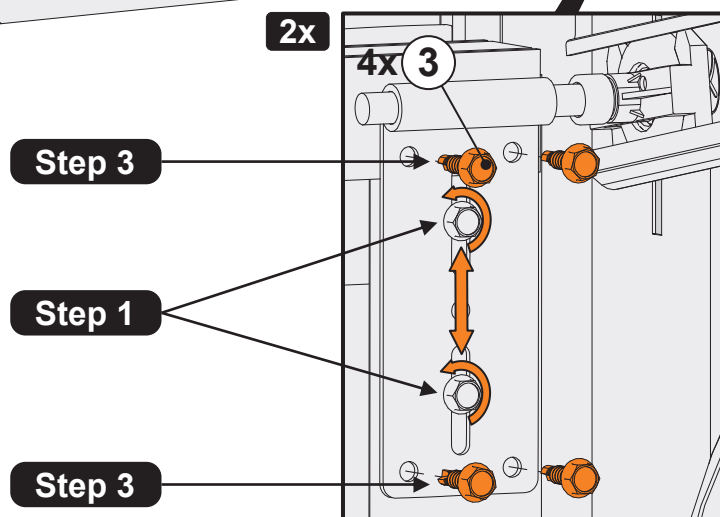
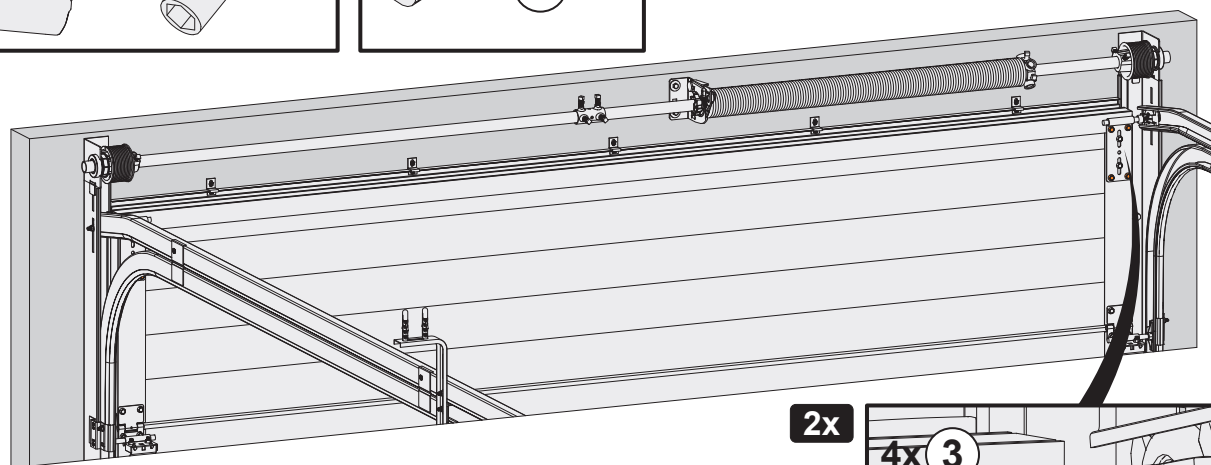
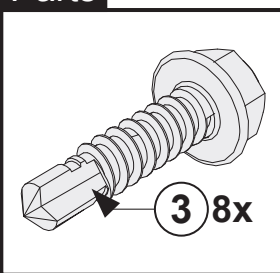

**Step 1** Release both central screws of the top roller bracket (23).

**Step 2** Position the panel with your hand against the lintel, and realign the top roller bracket (23).

**Step 3** Place the 4 bolts (3) in each top roller bracket (23) as shown in figure above and screw the 6 bolts (3) on each top roller bracket.

## 6.3 Conclusion of the installation of the door

- Set the position of the lateral hinges, so that the rollers are free to slide in the rails without effort. **(This is very important for quiet operation of the door).**

- After mounting, grease running part of the track the bearings and shafts of the rollers, the running part of the side hinges and intermediate hinges, the lock, the bearings of the shaft, the steel cables. Protect the panels with carwax. Grease the rubbers slightly with talcum powder.

- Remove the protective film from panels



**ATTENTION:** The panel is covered with an adhesive protective film PVC which is to be removed immediately after its installation (in the interior and exterior of the panels).

After complete the installation of the door, check that the door is in perfect working condition, that there aren't obstructions to opening the door, that all components are secure and adjusted. Before leaving the installation site you must pick up all the remaining packaging of the assembly, and place them in an appropriate dump.

# 7. Sectional door general view

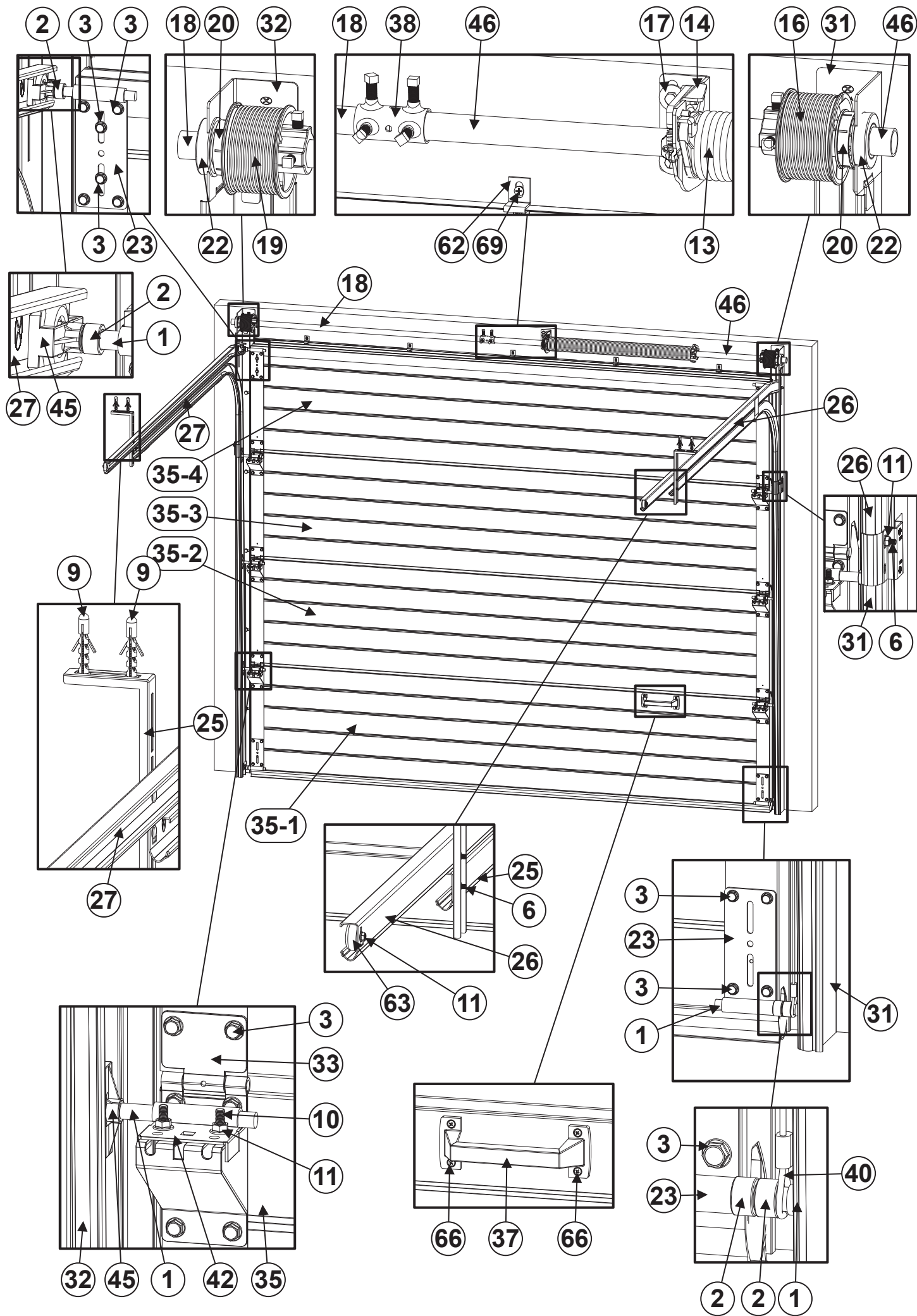



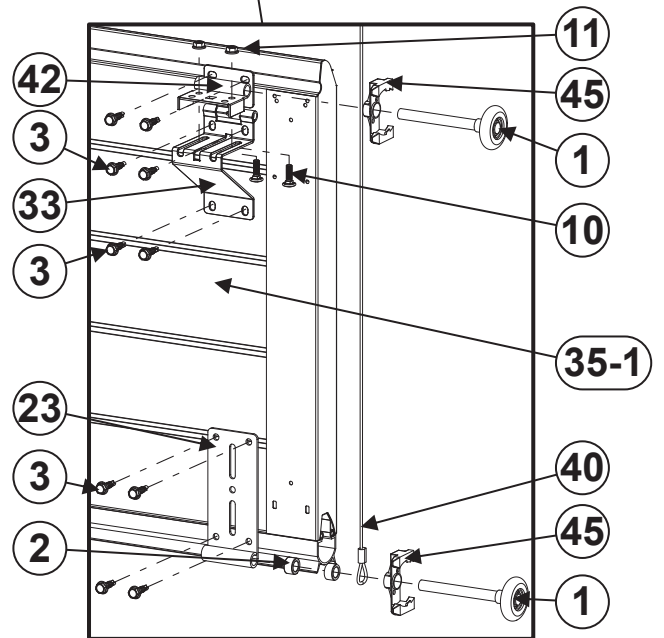
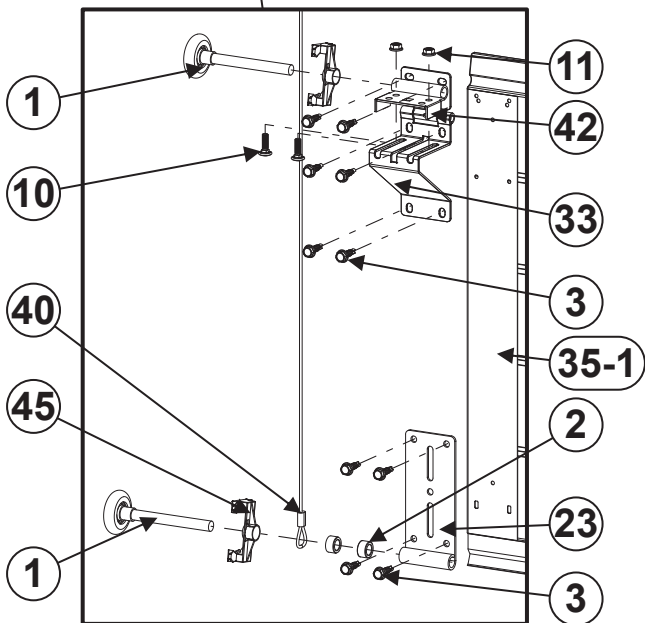
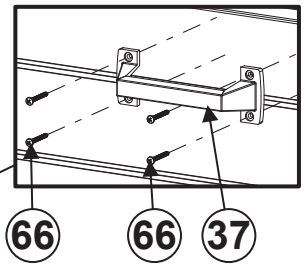
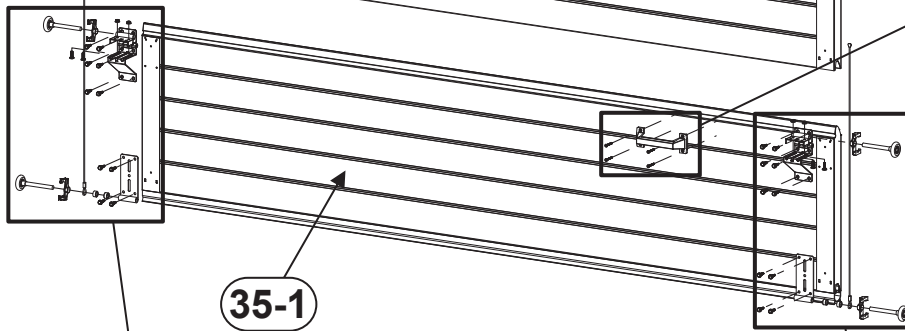
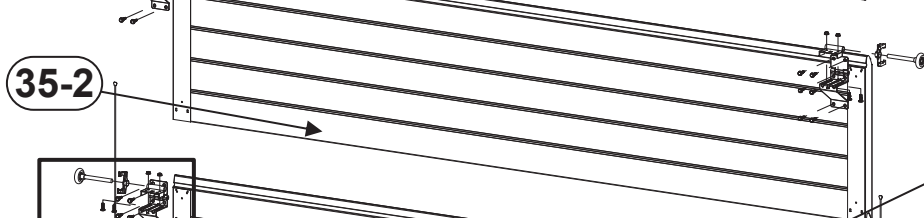
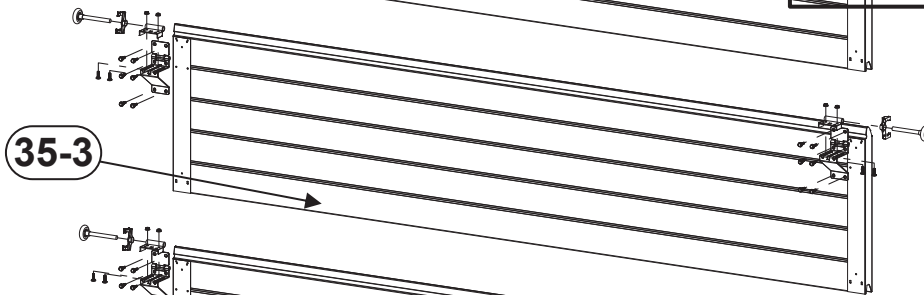
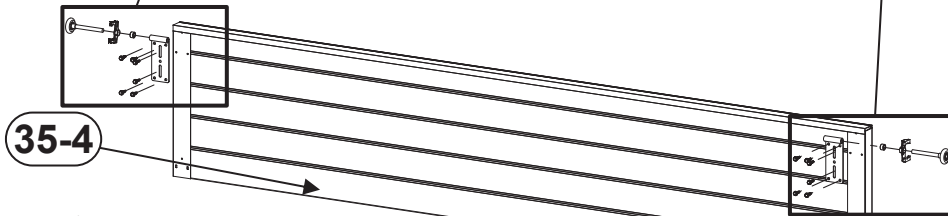
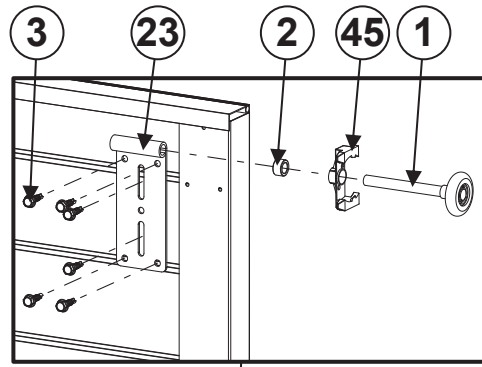
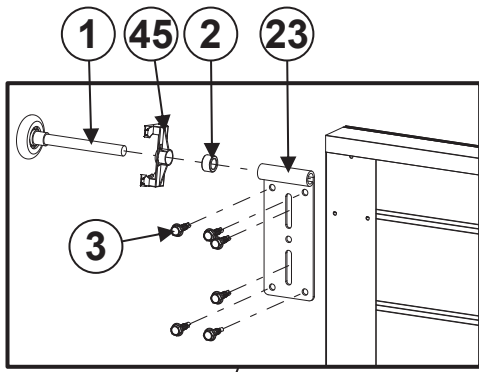

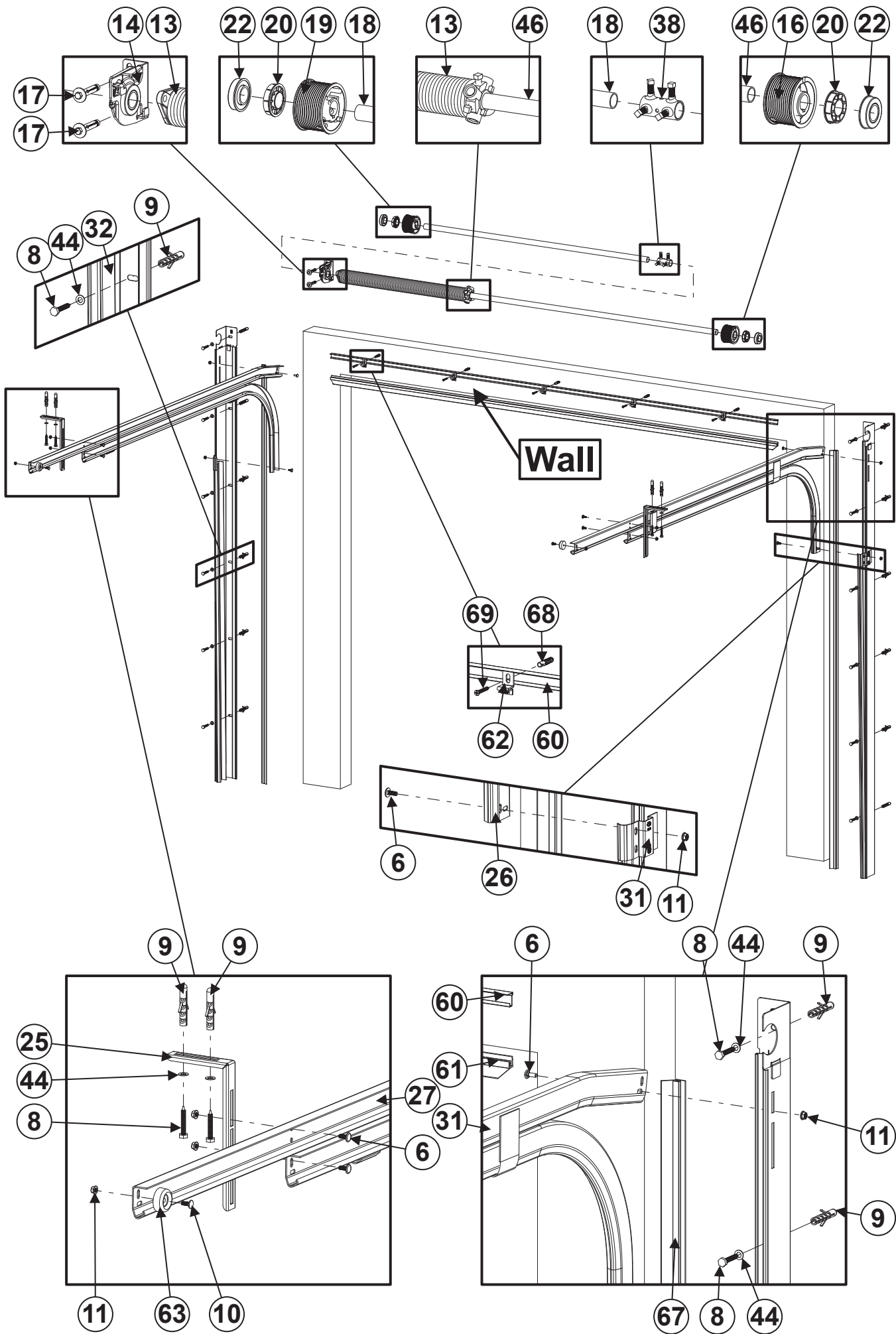

## 8. Maintenance and replacement parts

An overhead door should be maintained and checked regularly to ensure safe operation and use. This is described in the EN-norms. When you do the maintenance it is advisable to use the BOOK FOR REGISTRY OF MAINTENANCE FLEXIDOOR (This requirement is not necessary for non automatic operated vertically moving domestic garage used by one household only and which do not protrude directly, onto a public area outside the grounds of that household). Always use original parts to keep the door in accordance with the CE Marking.

### Général

1. Torsion springs, brackets and other components which are attached to the springs and cables, are under extreme tension. If not handled properly, injuries or damages might occur! **So, working on these components may only be carried out by qualified overhead door mechanics!**
2. Replacement of broken or weared components should always be done by qualified sectional door mechanics.
3. When checking the door, always disconnect the electrical main power supply. Make sure that it is blocked against re-engaging without you knowing it.

### MAINTENANCE:

#### Maintenance periodicity

The sectional door maintenance periodicity is indicated in the following table:

Sectional door for use	Criterion	Periodicity
Residential and Garage	N° of vehicles $\leq$ 5	12 months
	5 < N° of vehicles $\leq$ 50	6 months
	N° of vehicles > 50	3 months
	Seasonal use <sup>(1)</sup>	12 months
Industrial	-	6 months
Commercial	$\leq$ 10 cycles / day	6 months
	$\leq$ 10 cycles / day	4 months
Public, commercial, institutional buildings - with pass door	-	4 months
Public, commercial, institutional buildings - without pass door	-	3 months

<sup>(1)</sup> Sectional door used only in determined and short time periods (for example during the summer or on holidays)..

**The lines underlined are the maintenance that can be carried out by the end user.**

**The doors installed in front of the sea should be washed daily with drinking water, and if they are close to the sea at least once a week.**

#### After installation (level A):

1. Grease running part of the tracks.
2. Grease the bearings and shafts of the rollers.
3. Grease the running part of the side hinges and intermediate hinges.
4. Grease the lock.
5. Protect the panels with carwax.
6. Grease the rubbers slightly with talcum powder.
7. Grease the bearings of the shaft.
8. Grease the steel cables.

#### Every 3, 4 or 6 months, depending on the use of the sectional door (level B):

1. Complete inspection visually.
2. Check balancing system and adjust if needed.
3. Verify the adjustments of the engine (if it is an motorised door).
4. Check the functioning of the safety devices (Sensitive protection equipment, switches, photocells, etc.).
5. Check the manual operation of the door.
6. Check the functioning of the strength limiters.
7. Check the hinges on breaking.
8. Check the functioning and conditions of the existing signalling (flashing lights, illumination).
9. Check the motion transmission components (cables, chains, belts and articulated arms).
10. Grease and do the necessary adjustments for a correct door functioning.
11. Check the engine.

12. Check the side seals, top seals and bottom seals on damage or wear and tear.
13. Grease all above mentioned points (level A).
14. Clean the panels.
15. Clean the windows (only water wash, do not use cloth).
16. Remove dirt and waste from the door or its surroundings.
17. General review of the sectional door functioning.

**Every 12 months (level C):**

1. Complete inspection visually.
2. Check the door lock.
3. Check the tracks elements.
4. Check the roller on wear and free moving space in the tracks.
5. Verify the adjustments of the engine (if it is an motorised door).
6. Check the functioning of the safety devices (Sensitive protection equipment, switches, photocells, etc.).
7. Check the functioning of the strength limiters.
8. Check the remote control.
9. Check the balance of the door and adjust if needed.
10. Check the control board and its components.
11. Check the engine.
12. Check the connections of the track system.
13. Check the suspension of the door to the lintel and ceiling.
14. Check the cable break device (or bottom bracket) on wear and tear and damage\*.
15. Check or test the fixation of the springs to the fittings.
16. Check balancing system and adjust if needed.
17. Check the cables for damage or wear and tear.
18. Check the functioning and conditions of the existing signalling (flashing lights, illumination).
19. Check the motion transmission components (cables, chains, belts and articulated arms).
20. Check the cable connection points on drums and cable break device (or bottom bracket ).
21. Check the connection of the drum to the shaft (keys!).
22. Check the hinges on breaking.
23. Check the shaft on wear and tear or damage.
24. Check and re-fix the bolt of the coupler(if used).
25. Check the panels on damage, wear and roust.
26. Clean the panels.
27. Clean the windows (only water wash, do not use cloth).
28. Remove dirt and waste from the door or its surroundings.
29. Check the condition of painting and corrosion.
30. Check the spring breaking device acc. and remove the dust.
31. Check the side seals, top seals and bottom seals on damage or wear and tear.
32. Check and test the safety edge system with operator (if used).
33. Check the manual operation of the door.
34. Grease all the above mentioned points (levels A and B).
35. Grease the springs.
36. Grease and do the necessary adjustments for a correct door functioning.
37. General review of the sectional door functioning.

## \* Tests and maintenance of the cable break device:

### Tests - Verify if:

1. If the tape on the chisel is damaged, which can be caused by: The door has fallen due to cable breakage (track is damaged by the chisel). Follow the instructions: What to do after blocking.
  - The installer has to prevent the door from falling by supporting the bottom section (e.g. by placing the forks of a forklift truck under the section).
  - Lift the door panels so the chisel comes loose from the track and the U-brackets can be pivoted backwards. Block temporarily the U-bracket by placing a bolt or a nail into the hole.
  - Remove carefully the very sharp burr on the track which is caused by the chisel and/or repair the track in order to have a flush surface again (if necessary replace the track).
  - If the cable break device has been activated due to cable breakage, the device has to be replaced completely by a new one.
  - Check if other parts of the door like rollers, tracks etc. show any deformation resulting from the falling and blocking.
  - Remove the temporarily blocking.
2. The chisel touches the track.
3. If the chisel shows damages: replace the cable break device .
4. If the double torsion spring is broken, replace the cable break device.

### Maintenance

In principle the cable break device does not need maintenance. However, it is advisable to prevent dirt to enter or to removing it regularly.

## 9. Troubleshooting

### Torsion Spring:

**(The warrantie of the spring is given by an predictable number of operation cycles)**

**What to do if the spring break?**

**(Inform and instruct the user about this problem)**

After the spring breaks the door will be held by the spring brake device. Contact immediately an qualified technician. The spring brake is only for one use and should therefore be replaced, as well as other pieces that may have been damaged. The port must be inspected thoroughly.



**Replace the spring brake by a new.**



**Do not mess with no connection or door part after one spring breaks.**  
**Wait until a technician arrives to check the door!**

**Steel Cable: What to do if it breaks? (Inform and instruct the user about this problem).**

If the cable breaks the door is held by the second cable, which is sized to cope with the weight of the door. Call qualified technician to inspect the door and replace all parts that may have been damaged, such as brake cable, cable, tracks, rollers, etc.

## 10. Motor installation

When you select an electric motor, it must be installed in compliance with the manual supplied with the engine, and follow the instructions for handling the electrical equipment.

The technician who makes door installation must verify if the combination between the door and the engine is among those selected in the List of Engines with CE Marking for our door.

In order to help maintain the strength of the door in closing movement in accordance with EC standards, verify the correct installation position of the clamp arm (transmission) of the engine to the door.

**CAUTION:**

- The people can suffer injuries if the control software is not adjusted correctly, or if the control for the gate is not selected correctly!
  - After adjusting the motor, note if the peak power allowed in the closing movement of the gate is according with, CE Standards, among others.
  - If the engine has an exterior control box, it must be installed so that the person has a perfect view of the gate, away from moving parts and at a minimum height of 1,5 m.
  - In the case of remote controls, each control unit must clearly identify the machinery to be controlled from that unit.
- According to the standard EN 13241-1, in the chapter 6, Evaluation of conformity, part 6.1: "Where a door is the result of an in-situ assembly of products provided by several manufactures or suppliers the installer is assumed to be the manufacturer".

For example, if the installer applies an engine that is not on the list of certified engines to the sectional door in question, the installer is considered as being the door manufacturer. In this case the installer will do all the necessary tests defined in European standards, on notified body.

## **11. Instructions of Operation, Use and Maintenance**

### **11.1 Documentation delivered**

The following documentation must be given to the owner of the door at the end of the installation:

- Instructions for operation and maintenance.
- Document to register each intervention to monitor the maintenance the door.
- The declaration of performance that ensures compliance of the door according to the requirements of EN 13241-1.

### **11.2 User instructions**

#### **Manual and /or Motorized door**

- Always check before any maneuver that near of the door there are no persons, animals or objects that may interfere with its proper operation;
- Do not put any objects in the influence area of the door that may cause damages;
- Always check that no people or animal are enclosed;
- For greater protection, the gate can be closed from the inside with the slide bolt or the lock;
- Avoid the partial opening of the door to reduce the risks to the passage of persons, animal or damages to objects or good;
- Operate the door under adverse wind conditions may be dangerous;
- Do not put your fingers between the different sections of the door. If you need to open or close the door manually, use the handles;
- Verify if adjacent persons are not exposed to any risk of crushing, cutting, shearing, entanglement, drawing-in (e.g. limbs, hair or cloths) and trapping in the opening and closing movement of the door;
- Verify if the windows or their components are not likely to grab people (limbs, hair or clothing) during movement the opening and closing of the door;

#### **Motorized door**

##### **Verify that:**

- The motor have electrical power;
- The remote control has good batteries and that is the remote of this door;
- If it is necessary to use the door in manual mode, make sure the engine is unlocked. To unlock the motor, pull the cord down;

##### **As a precaution, make sure that:**

- The remote control stays out of reach of children

### **11.3 Operating instructions**

- The door have certificate up to 15000 cycles;
- The door have a Resistance to Wind load Class 2 (98Km/h) (EN 12424);
- The climatic conditions of operation for which the security elements are able to work should be between -20°C and +50°C;
- The door operation mode: Manual, Motorized and Semi-Automatic;
- The sectional door is designed for use residential;
- The door comes equipped with the spring break device in the central position of the shaft;
- Follow the manual instructions of the motor that will be installed in the sectional door;

## **12. Dismantling the sectional door**

 **ATTENTION/WARNING:** To dismantle an existing sectional door, a number of precautions must be taken. For the safety of all concerned pay heed to the warnings and instructions given below! If in doubt, contact your supplier or Flexidoor.

Dismantling should only be carried out by experienced fitters. This manual is not suitable for d.i.y. purposes or for use by trainee fitters. This manual only describes the installation/dismantling of hardware for sectional doors and as such must be supplemented with instructions for any additional components.

 **CAUTION!** Torsion springs and bottom brackets are under high tension. Exercise at all times great caution. Use properly fitting and maintained tension irons.

**STEP 1.** De-tensioning the torsion spring(s)

 **Start dismantling of the door by closing the door and securing its movement with a clamp on the vertical track.**

First the tension on the torsions springs and cable has to be released. Do this by following these instructions:

1. Insert the 1st tension bar fully into the tensioning aperture.
2. Take over the tension of the spring with this tension bar and loosen the bolts in the tension bar and remove the key.
3. Turn the 1st tensioning iron in the direction required.
4. Insert the 2nd tensioning iron fully into the next tensioning aperture.
5. Take over the tensioning of the spring from the 1st tension bar with the 2nd tension bar.
6. Remove the 1st tensioning iron from the aperture.
7. Turn the 2nd tension bar a quarter turn in the direction require and insert the 1st tension bar fully into the tensioning aperture.
8. Take over the tensioning of the spring from the 2nd tension bar with the 1st tension bar.
9. Repeat steps 3 through 8 until all tension is released.
10. Remove the last tension bar.

**STEP 2.** Disconnect the electrical operator. Follow any instructions given in the separate manual of the operator.

**STEP 3.** Loosen the cable drums and remove the keys. Act carefully, there might be some tension left on the cable. Check if the cable is slack. Remove the cable by disconnecting it from the cable break device (or bottom bracket) and cable drum.

**STEP 4.** Dismantle the horizontal track.

**STEP 5.** Remove the panels one by one from the vertical track construction, starting with the top panel. Do this by loosening the hinges and rollers first.

**STEP 6.** Remove the shaft construction from the lintel, after you have dismantled the E-operator from the shaft. If the shaft is divided and connected with a coupler, first disconnect the coupler and carefully remove both halves of the shaft system.

 **Attention!** Watch out for parts that might slide of the shaft, such as cable drums, bearings or keys.

**STEP 7.** Remove vertical tracks and angles from the building construction.

**STEP 8.** Make sure that you remove all the parts and panels in an environment kindly way. Check with your local authorities where and how you can leave this as garbage.

**FOR ANY DETAILS ON THESE DISMANTLING INSTRUCTIONS, WE REFER TO THE INSTALLATION CHAPTERS OF THIS MANUAL WHERE DRAWINGS AND DETAILS ARE DISPLAYED.**

## WARRANTY

The FLEXIDOOR ensures that the Residential Sectional Doors (ahead referred as “Door”) are free from defects in material and manufacture, in the date of its original sale, ensuring that it is subject to the following terms and conditions:

1. This guarantee is given to the final purchaser of the Door (“Customer”). It does not exclude or limit:
  - i) Any rights of the Customer given by the imperative law; or
  - ii) Any rights of the Customer given from seller/dealer of the Product.
2. The warranty period is twenty four (24) months counting from the date of purchase of the door made by the first customer. In the event of a subsequent purchase or change of owner / user, such warranty period will continue for the remaining period of twenty four (24) months and remain unchanged in all other respects.
3. During the warranty period, the FLEXIDOOR or a repair company authorized by FLEXIDOOR will repair or replace, in its exclusive decision, a defective door and / or parts that are defective. The FLEXIDOOR will return the repaired a door, another door or other defective parts in good working conditions. All parts or equipment which have been replaced will be property of FLEXIDOOR.
4. The repair or replacement of a door or defective parts, does not extend or renew the warranty period.
5. This warranty will not apply in deteriorations resulting from normal use and wear. This warranty Nor will apply if:
  - i) the defect was caused by the fact that the Port have been subjected to: use in contradiction with what is described in the user’s manual, careless handling, installation by non-specialist, exposure to extreme thermal or environmental conditions, or sudden changes of such conditions; corrosion, oxidation, unauthorized opening or connections, or unauthorized repair, repair by use of parts not authorized, improper installation, accident, forces of nature, influence of the sea, influence of chemicals or other acts beyond the reasonable control of FLEXIDOOR (including, in particular, deficiencies in consumable parts), unless the defect was caused directly by defects in design or manufacture;
  - ii) FLEXIDOOR or the repair company authorized by Flexidoor has not been notified of the defect by the customer within thirty (30) days after the defect appear within the warranty period;
  - iii) the serial number of the door or any seal or identifying element has been removed, erased, defaced, altered or is illegible;
  - iv) the serial number of the door matches a device in which a theft was reported by its original purchaser, subject to notification to the authorities.
6. To claim this guarantee, the Customer must exhibit:
  - i) copy of purchase invoice, which clearly indicates the name and address of the purchaser, the date and place of purchase, the type of door or, alternatively:
  - ii) an original receipt, legible and not altered, which contains the same information.
7. The warranty covers the parts without the cost of transport.
8. This guarantee constitutes the only source of responsibility of FLEXIDOOR to the Customer regarding defects or defective functioning of the Door. This warranty supersedes all other warranties and liabilities, whether oral, written, legislative provisions (non-mandatory), contractual, relative the repairing of damages or others. In no event FLEXIDOOR is responsible for accidental damages, indirect or subsequent, costs or expenses. The FLEXIDOOR nor is it responsible in any circumstances for any direct damage, costs or expenses, if the Customer is a collective person.
9. The FLEXIDOOR is not in any way forced to exchange or refund cost of purchase of doors if the client later comer to evidence that the door does not to have the characteristics desired for themselves. It is understood that all the necessary technical data were already provided in the moment of choosing the door or purchase decision. Nevertheless, if the package has not been violated, the FLEXIDOOR can decide to credit the value in customer’s checking account for future purchases.
10. Any alteration or amendment to the present warranty shall be valid only if previously authorized, in writing, by FLEXIDOOR.



## WARRANTY OF SPRINGS

Dear Customer:

For the time warranty of the springs, we hereby inform you of the following:

The springs lifetime on overhead door refers to the number of cycles in which it can operate up to the moment of fatigue failure, which means that the spring loses its characteristics of elasticity, and fails to compensate the weight of the door correctly. As described, the life of the spring is not expected in time but in cycles, being each cycle the process of opening and closing the door. So if you know the number of cycles the door will operate its possible to estimate the life-time of the spring.

The life of a spring depends not only on the quality of the spring but it also depends on the level of demand that it is exposed, depending on the specific characteristics of the door. Thus, one same spring (same type of wire, same dimensions) will have a shorter life time in a door with higher demands (weight, drum type, number of turns of torsion in the spring, etc.) than another door "less demanding" depending much on the correct installation and maintenance of the door. It is essential to ensure that the door is well balanced and that it works without effort.

Due to the previous reasons, it is not possible to emit a certificate or a generic declaration on the guarantee of lifetime warranty for the springs.

Flexidoor uses the vast experience of the supplier in manufacturing and application of springs for sectional doors, which tabled the conditions of use of each type of spring both to balance weight, as the level of estimation of life in number of cycles. Based on these tables, given the concrete conditions of each door and knowing the number of cycles required (minimum of 15,000 cycles in the CE Marking for Flexidoor), we obtain one or more solutions of springs for that door, through the selection program.

Thus, the estimated life of a spring depends on the criterion of the client to choose the springs, since he can choose springs with a higher number of cycles, for cases such as condominiums and gates with a very intensive use.

We must emphasize that the solutions obtained with the program selection is only guaranteed for the springs provided by FLEXIDOOR.

We also would like to point out that, as described, the quality of the spring is not the only parameter that affects the life of the same, being perhaps most important, since the quality of the wire that is manufactured, as well as the thermal treatment that it is applied are the key to the functioning of the spring. The springs are produced from wire of quality EN 10270-1 SH, which is provided by certified suppliers.

# BOOK FOR REGISTRY OF MAINTENANCE

(Data to be completed by the technician before handing over to client)

## Technical Data of Door and Installation

Company Name: \_\_\_\_\_

Address: \_\_\_\_\_ Contact: \_\_\_\_\_

Installation Date: \_\_\_ / \_\_\_ / \_\_\_\_\_ Plate Serial Number of Door (O.F.): \_\_\_ / \_\_\_ / \_\_\_\_\_

Customer: \_\_\_\_\_ Contact: \_\_\_\_\_

Work Location: \_\_\_\_\_

Manufacturer: FLEXIDOOR - Portões Seccionados e Automatismos, S.A.

Address: Quinta São João das Areias

Rua A, Lote 62

Contact: 2685-012 Sacavém - Portugal Tel.: +351 244 850 470 Fax: +351 244 850 471

### List of Safety Devices Used

Make the description of the security devices used

Engine: \_\_\_\_\_ Model, type \_\_\_\_\_

Electric Board: \_\_\_\_\_ Model, type \_\_\_\_\_

Photocells: \_\_\_\_\_ Model, type \_\_\_\_\_

Comand Device: \_\_\_\_\_ Model, type \_\_\_\_\_

Other: \_\_\_\_\_ Model, type \_\_\_\_\_

Other: \_\_\_\_\_ Model, type \_\_\_\_\_

## Description of Intervention

(Signal X in the intervention made, and describe the work of the intervention, tuning parameters of the engine as well as possible errors in use)

Assembly  Test  Maintenance  Repair  Modification

Date: \_\_\_ / \_\_\_ / \_\_\_\_\_ Customer signature: \_\_\_\_\_

Installer name: \_\_\_\_\_ Installer signature: \_\_\_\_\_

## Description of Intervention

(Signal X in the intervention made, and describe the work of the intervention, tuning parameters of the engine as well as possible errors in use)

Assembly  Test  Maintenance  Repair  Modification

Date: \_\_\_ / \_\_\_ / \_\_\_\_\_ Customer signature: \_\_\_\_\_

Installer name: \_\_\_\_\_ Installer signature: \_\_\_\_\_

## Description of Intervention

(Signal X in the intervention made, and describe the work of the intervention, tuning parameters of the engine as well as possible errors in use)

Assembly  Test  Maintenance  Repair  Modification

Date: \_\_\_ / \_\_\_ / \_\_\_\_\_ Customer signature: \_\_\_\_\_

Installer name: \_\_\_\_\_ Installer signature: \_\_\_\_\_

### Description of Intervention

(Signal X in the intervention made, and describe the work of the intervention, tuning parameters of the engine as well as possible errors in use)

Assembly  Test  Maintenance  Repair  Modification

Date: \_\_\_ / \_\_\_ / \_\_\_ Customer signature: \_\_\_\_\_

Installer name: \_\_\_\_\_ Installer signature: \_\_\_\_\_

### Description of Intervention

(Signal X in the intervention made, and describe the work of the intervention, tuning parameters of the engine as well as possible errors in use)

Assembly  Test  Maintenance  Repair  Modification

Date: \_\_\_ / \_\_\_ / \_\_\_ Customer signature: \_\_\_\_\_

Installer name: \_\_\_\_\_ Installer signature: \_\_\_\_\_

### Description of Intervention

(Signal X in the intervention made, and describe the work of the intervention, tuning parameters of the engine as well as possible errors in use)

Assembly  Test  Maintenance  Repair  Modification

Date: \_\_\_ / \_\_\_ / \_\_\_ Customer signature: \_\_\_\_\_

Installer name: \_\_\_\_\_ Installer signature: \_\_\_\_\_

### Description of Intervention

(Signal X in the intervention made, and describe the work of the intervention, tuning parameters of the engine as well as possible errors in use)

Assembly  Test  Maintenance  Repair  Modification

Date: \_\_\_ / \_\_\_ / \_\_\_ Customer signature: \_\_\_\_\_

Installer name: \_\_\_\_\_ Installer signature: \_\_\_\_\_

### Description de l'Intervention

(Indiquez avec une X l'intervention effectuée et décrire le travail effectué lors de l'intervention, les paramètres d'ajustement du moteur et des possibles erreurs d'utilisation)

Inspection  Essais  Maintenance  Réparation  Modification

Date: \_\_\_ / \_\_\_ / \_\_\_ Signature du Client: \_\_\_\_\_

Nom du Technicien: \_\_\_\_\_ Signature Technicien: \_\_\_\_\_

### Description of Intervention

(Signal X in the intervention made, and describe the work of the intervention, tuning parameters of the engine as well as possible errors in use)

Assembly  Test  Maintenance  Repair  Modification

Date: \_\_\_ / \_\_\_ / \_\_\_ Customer signature: \_\_\_\_\_  
Installer name: \_\_\_\_\_ Installer signature: \_\_\_\_\_

### Description of Intervention

(Signal X in the intervention made, and describe the work of the intervention, tuning parameters of the engine as well as possible errors in use)

Assembly  Test  Maintenance  Repair  Modification

Date: \_\_\_ / \_\_\_ / \_\_\_ Customer signature: \_\_\_\_\_  
Installer name: \_\_\_\_\_ Installer signature: \_\_\_\_\_

### Description of Intervention

(Signal X in the intervention made, and describe the work of the intervention, tuning parameters of the engine as well as possible errors in use)

Assembly  Test  Maintenance  Repair  Modification

Date: \_\_\_ / \_\_\_ / \_\_\_ Customer signature: \_\_\_\_\_  
Installer name: \_\_\_\_\_ Installer signature: \_\_\_\_\_

### Description of Intervention

(Signal X in the intervention made, and describe the work of the intervention, tuning parameters of the engine as well as possible errors in use)

Assembly  Test  Maintenance  Repair  Modification

Date: \_\_\_ / \_\_\_ / \_\_\_ Customer signature: \_\_\_\_\_  
Installer name: \_\_\_\_\_ Installer signature: \_\_\_\_\_

### Description de l'Intervention

(Indiquez avec une X l'intervention effectuée et décrire le travail effectué lors de l'intervention, les paramètres d'ajustement du moteur et des possibles erreurs d'utilisation)

Inspection  Essais  Maintenance  Réparation  Modification

Date: \_\_\_ / \_\_\_ / \_\_\_ Signature du Client: \_\_\_\_\_  
Nom du Technicien: \_\_\_\_\_ Signature Technicien: \_\_\_\_\_

### Description of Intervention

(Signal X in the intervention made, and describe the work of the intervention, tuning parameters of the engine as well as possible errors in use)

Assembly  Test  Maintenance  Repair  Modification

Date: \_\_\_ / \_\_\_ / \_\_\_ Customer signature: \_\_\_\_\_

Installer name: \_\_\_\_\_ Installer signature: \_\_\_\_\_

### Description of Intervention

(Signal X in the intervention made, and describe the work of the intervention, tuning parameters of the engine as well as possible errors in use)

Assembly  Test  Maintenance  Repair  Modification

Date: \_\_\_ / \_\_\_ / \_\_\_ Customer signature: \_\_\_\_\_

Installer name: \_\_\_\_\_ Installer signature: \_\_\_\_\_

### Description of Intervention

(Signal X in the intervention made, and describe the work of the intervention, tuning parameters of the engine as well as possible errors in use)

Assembly  Test  Maintenance  Repair  Modification

Date: \_\_\_ / \_\_\_ / \_\_\_ Customer signature: \_\_\_\_\_

Installer name: \_\_\_\_\_ Installer signature: \_\_\_\_\_

### Description of Intervention

(Signal X in the intervention made, and describe the work of the intervention, tuning parameters of the engine as well as possible errors in use)

Assembly  Test  Maintenance  Repair  Modification

Date: \_\_\_ / \_\_\_ / \_\_\_ Customer signature: \_\_\_\_\_

Installer name: \_\_\_\_\_ Installer signature: \_\_\_\_\_

### Description de l'Intervention

(Indiquez avec une X l'intervention effectuée et décrire le travail effectué lors de l'intervention, les paramètres d'ajustement du moteur et des possibles erreurs d'utilisation)

Inspection  Essais  Maintenance  Réparation  Modification

Date: \_\_\_ / \_\_\_ / \_\_\_ Signature du Client: \_\_\_\_\_

Nom du Technicien: \_\_\_\_\_ Signature Technicien: \_\_\_\_\_

### Description of Intervention

(Signal X in the intervention made, and describe the work of the intervention, tuning parameters of the engine as well as possible errors in use)

Assembly  Test  Maintenance  Repair  Modification

Date: \_\_\_ / \_\_\_ / \_\_\_ Customer signature: \_\_\_\_\_  
Installer name: \_\_\_\_\_ Installer signature: \_\_\_\_\_

### Description of Intervention

(Signal X in the intervention made, and describe the work of the intervention, tuning parameters of the engine as well as possible errors in use)

Assembly  Test  Maintenance  Repair  Modification

Date: \_\_\_ / \_\_\_ / \_\_\_ Customer signature: \_\_\_\_\_  
Installer name: \_\_\_\_\_ Installer signature: \_\_\_\_\_

### Description of Intervention

(Signal X in the intervention made, and describe the work of the intervention, tuning parameters of the engine as well as possible errors in use)

Assembly  Test  Maintenance  Repair  Modification

Date: \_\_\_ / \_\_\_ / \_\_\_ Customer signature: \_\_\_\_\_  
Installer name: \_\_\_\_\_ Installer signature: \_\_\_\_\_

### Description of Intervention

(Signal X in the intervention made, and describe the work of the intervention, tuning parameters of the engine as well as possible errors in use)

Assembly  Test  Maintenance  Repair  Modification

Date: \_\_\_ / \_\_\_ / \_\_\_ Customer signature: \_\_\_\_\_  
Installer name: \_\_\_\_\_ Installer signature: \_\_\_\_\_

### Description de l'Intervention

(Indiquez avec une X l'intervention effectuée et décrire le travail effectué lors de l'intervention, les paramètres d'ajustement du moteur et des possibles erreurs d'utilisation)

Inspection  Essais  Maintenance  Réparation  Modification

Date: \_\_\_ / \_\_\_ / \_\_\_ Signature du Client: \_\_\_\_\_  
Nom du Technicien: \_\_\_\_\_ Signature Technicien: \_\_\_\_\_

### Description of Intervention

(Signal X in the intervention made, and describe the work of the intervention, tuning parameters of the engine as well as possible errors in use)

Assembly  Test  Maintenance  Repair  Modification

Date: \_\_\_ / \_\_\_ / \_\_\_ Customer signature: \_\_\_\_\_

Installer name: \_\_\_\_\_ Installer signature: \_\_\_\_\_

### Description of Intervention

(Signal X in the intervention made, and describe the work of the intervention, tuning parameters of the engine as well as possible errors in use)

Assembly  Test  Maintenance  Repair  Modification

Date: \_\_\_ / \_\_\_ / \_\_\_ Customer signature: \_\_\_\_\_

Installer name: \_\_\_\_\_ Installer signature: \_\_\_\_\_

### Description of Intervention

(Signal X in the intervention made, and describe the work of the intervention, tuning parameters of the engine as well as possible errors in use)

Assembly  Test  Maintenance  Repair  Modification

Date: \_\_\_ / \_\_\_ / \_\_\_ Customer signature: \_\_\_\_\_

Installer name: \_\_\_\_\_ Installer signature: \_\_\_\_\_

### Description of Intervention

(Signal X in the intervention made, and describe the work of the intervention, tuning parameters of the engine as well as possible errors in use)

Assembly  Test  Maintenance  Repair  Modification

Date: \_\_\_ / \_\_\_ / \_\_\_ Customer signature: \_\_\_\_\_

Installer name: \_\_\_\_\_ Installer signature: \_\_\_\_\_

### Description de l'Intervention

(Indiquez avec une X l'intervention effectuée et décrire le travail effectué lors de l'intervention, les paramètres d'ajustement du moteur et des possibles erreurs d'utilisation)

Inspection  Essais  Maintenance  Réparation  Modification

Date: \_\_\_ / \_\_\_ / \_\_\_ Signature du Client: \_\_\_\_\_

Nom du Technicien: \_\_\_\_\_ Signature Technicien: \_\_\_\_\_



**Flexidoor**<sup>®</sup>  
AUTOMATIC DOORS MANUFACTURER



All rights reserved of the product and owner's manual. It prohibited the duplication, rent and public use of it.